



AIRPORT COMMISSION MEETING AGENDA
 Airport Conference Room, Palm Springs International Airport
 3400 E. Tahquitz Canyon Way, Palm Springs, CA 92262
 Wednesday, March 18, 2026 - 4:00 P.M.

To view/listen/participate virtually in the meeting live, please contact the administration office at psp.commission@palmspringsca.gov to register for the Zoom meeting. There will be an email with Zoom credentials sent after registration is complete, to access the meeting and offer public comment. Registration is not required to attend the meeting in person.

In addition, the meeting will also be teleconferenced pursuant to Government Code Section 54953 from the following location(s):

Commissioner Christian Samlaska – Cathedral City 30950 Avenida Del Yermo Cathedral City, Ca 92234	Commissioner Kevin Wiseman –Palm Desert 71-703 Highway 111, Suite 2E Rancho Mirage, CA 92270
--	--

Each location is accessible to the public, and members of the public may address the Airport Commission at any of the locations listed above. Any person who wishes to provide public testimony in public comments is requested to register for the Public Comments portion of the meeting. You may submit your public comments to the Airport Commission electronically. Material may be emailed to: psp.commission@palmspringsca.gov. Transmittal prior to the start of the meeting is required. Any correspondence received during or after the meeting will be distributed to the Airport Commission and retained for the official record. To view Airport Commission meeting videos, click on [YouTube](#).

City of Palm Springs:		Riverside County: Margaret Park	City of Cathedral City: Christian Samlaska	City of Palm Desert: Kevin Wiseman
Kevin J. Corcoran – Chairman	Todd Burke – Vice Chairman			
Daniel Caldwell	Tracy Martin	City of Indian Wells: Phil Valdez	City of Coachella: Denise Delgado	City of Rancho Mirage: Keith Young
Bryan Ebensteiner	Samantha McDermott			
J Craig Fong	Timothy Schoeffler	City of La Quinta: Geoffrey Kiehl	City of Desert Hot Springs: Dirk Voss	City of Indio: Rick Wise
Ken Hedrick	Vacant			
Palm Springs City Staff				
Scott C. Stiles, ICMA-CM	Harry Barrett Jr., A.A.E.	Jeremy Keating, C.M.	Victoria Carpenter, C.M.	
City Manager	Executive Director or Aviation	Assistant Airport Director	Assistant Airport Director	

1. CALL TO ORDER – PLEDGE OF ALLEGIANCE

2. POSTING OF AGENDA

3. ROLL CALL

4. ACCEPTANCE OF AGENDA

5. PUBLIC COMMENTS:

Limited to three minutes on any subject within the purview of the Commission.

6. APPROVAL OF MINUTES:

6.A Minutes of the Airport Commission Regular Meeting of February 18, 2026.

7. DISCUSSION AND ACTION ITEMS:

- 7.A** Parking Access and Revenue Control System (PARCS) Update
- 7.B** Marketing and Business Development Committee Meeting Update
- 7.C** Strategic Plan Quarterly Update
- 7.D** Art Program Update
- 7.E** Financial Update
- 7.F** Projects and Airport Capital Improvement Program Update
- 7.G** Marketing Update
- 7.H** Future City Council Update

8. ASSISTANT DIRECTOR REPORT

9. COMMISSIONERS REQUESTS AND REPORTS

10. REPORT OF COUNCIL ACTIONS:

10.A Past City Council Actions

11. RECEIVE AND FILE:

- 11.A** Airline Activity Report February 2026
- 11.B** Airline Activity Report Fiscal Year Comparison
- 11.C** Request for Proposal (RFP) and Invitation for Bid (IFB) Update

12. COMMITTEES:

- 12.A** Future Committee Meetings
- 12.B** Committees Roster

13. ADJOURNMENT:

The Airport Commission will adjourn to the Regular Meeting on April 15, 2026, at 4:00 P.M.

AFFIDAVIT OF POSTING

I, Harry Barrett, Jr., Executive Director of Aviation, City of Palm Springs, California, hereby certify this agenda was posted on March 12, 2026, in accordance with established policies and procedures.

PUBLIC NOTICES

Pursuant to G.C. Section 54957.5(b)(2) the designated office for inspection of records in connection with the meeting is the Office of the City Clerk, City Hall, 3200 E. Tahquitz Canyon Way. Complete Agenda Packets are available for public inspection at: City Hall Office of the City Clerk. Agenda and staff reports are available on the City's website www.palmspringsca.gov. If you would like additional information on any item appearing on this agenda, please contact the Office of the City Clerk at (760) 323-8204.

It is the intention of the City of Palm Springs to comply with the Americans with Disabilities Act (ADA) in all respects. If, as an attendee or a participant at this meeting, or in meetings on a regular basis, you will need special assistance beyond what is normally provided, the City will attempt to accommodate you in every reasonable manner. Please contact the Department of Aviation, (760) 318-3800, at least 48 hours prior to the meeting to inform us of your particular needs and to determine if accommodation is feasible.



palm springs
INTERNATIONAL AIRPORT

AIRPORT COMMISSION

**MINUTES OF THE REGULAR MEETING OF THE AIRPORT COMMISSION OF
THE PALM SPRINGS INTERNATIONAL AIRPORT**

Wednesday, February 18, 2026 - 4:00 P.M.

1. CALL TO ORDER:

Chairman Corcoran called the Airport Commission meeting to order at 4:00 P.M. The meeting was held in-person and via videoconference.

Chairman Corcoran asked Commissioner McDermott to lead the Pledge of Allegiance.

2. POSTING OF AGENDA: Agenda posted on February 12, 2026.

3. ROLL CALL:

Commissioner’s Present:

Todd Burke (Palm Springs) Vice Chairman	Christian Samlaska (Cathedral City)
Kevin Corcoran (Palm Springs) - Chairman	Timothy Schoeffler (Palm Springs)
J Craig Fong (Palm Springs)	Phil Valdez (Indian Wells)
Ken Hedrick (Palm Springs)	Rick Wise (Indio)
Geoffrey Kiehl (La Quinta)	Keith Young (Rancho Mirage)
Tracy Martin (Palm Springs)	Margaret Park (Riverside County)
Samantha McDermott (Palm Springs)	

Commissioners Absent: Daniel Caldwell (Palm Springs), Bryan Ebensteiner (Palm Springs), Dirk Voss (Desert Hot Springs), Kevin Wiseman (Palm Desert)

Staff Present:

Harry Barrett, Jr., Executive Director of Aviation
 Jeremy Keating, Assistant Airport Director
 Victoria Carpenter, Assistant Airport Director
 Daniel Meier, Deputy Director of Aviation, Marketing and Air Service
 Ryan Kaspari, Deputy Director of Capital Development

Airport Commission Minutes
February 18, 2026

Lowell Valencia - Miller, Executive Program Administrator
Christina Brown, Executive Program Administrator
Harman Singh, Project Manager
Ramon Sanchez, Operations Manager
Ed Graff, Operations Manager
Tom Woodard, Airport Emergency Planning Administrator
Jake Ingrassia, Marketing and Communications Specialist
Jason Hodges, Strategy and Innovation Administrator
Mariana Anguiano, Executive Administrative Assistant
Tanya Perez, Administrative Specialist
Jeremy Holm, City Attorney

Others Present:

Teva Dawson Group Creative Services LLC.

4. ACCEPTANCE OF AGENDA:

MOTION BY COMMISSIONER FONG, SECOND BY COMMISSIONER YOUNG, CARRIED UNANIMOUSLY, to approve the agenda as presented.

5. PUBLIC COMMENTS:

Brandon Weimer, Representing Brandini Toffee gave a public comment on Item 7.C Retail, Food, and Beverage Blank Slate Concessions Space.

Bonnie Bronson, gave a public comment on Item 7.A Regulatory Framework Governing Aircraft Noise.

Claude Peck, gave a public comment Item 7.A Regulatory Framework Governing Aircraft Noise.

Athena Sippel, Representing The Kids Bakery (TKB) gave a public comment on Item 7.C Retail, Food, and Beverage Blank Slate Concessions Space.

6. APPROVAL OF MINUTES:

6.A Minutes of the Airport Commission Meeting of January 21, 2026.

MOTION BY COMMISSIONER SCHOELLFER, SECOND BY COMMISSIONER YOUNG, CARRIED 9 – YES, WITH COMMISSIONERS KIEHL, MCDERMOTT AND PARK -ABSTAINED to approve the minutes of JANUARY 21, 2026.

7. DISCUSSION AND ACTION ITEMS:

7.A Regulatory Framework Governing Aircraft Noise

Marketing and Communications Specialist, Ingrassia presented to the Commission on community concerns regarding aircraft noise following Federal Aviation Administration (FAA) flight path changes. PSP staff explained that the airport manages on-ground operations, while the FAA controls in-air flight paths, outlined ongoing noise mitigation efforts, and encouraged residents to submit concerns via PSP's online form or directly to the FAA.

7.B Development of Art Budget and Art Program

Executive Program Manager, Brown and Teva Dawson with Group Creative Services presented the Airport art program, and the Commission approved the FY26–27 budget, funding allocations, and maintenance support, emphasizing local artists and tribal cultural representation, with plans to integrate art into capital projects and begin installations in May 2026.

MOTION BY COMMISSIONER WISE, SECOND BY BURKE TO APPROVE AND IMPLEMENT A CAP OF FUNDS FROM THE 1% LOCAL MATCH ALLOCATIONS AND TO INCLUDE AN ANNUAL AIRPORT OPERATIONS AND MAINTENANCE BUDGET AS WELL AS A RECOMMENDATION THAT GROUP CREATIVE SERVICES HAVE AN ART INSTALLATION BY MAY 2026. VOTE: YES - UNANIMOUSLY.

7.C Retail, Food, and Beverage Blank Slate Concessions Space

Executive Program Administrator, Valencia-Miller gave an update.

7.D Earthquake Preparedness

Airport Emergency Planning Administrator, Woodard presented.

7.E Marketing and Business Development Committee Meeting Update

Chairman Corcoran provided an update along with Strategy and Innovation Administrator, Hodges on FUSE lobby space.

7.F Operations, Properties, and Facilities Committee Meeting Update

Assistant Airport Director, Carpenter along with Operations Manager Graff provided an update.

7.G Marketing Update

Deputy Director of Aviation Marketing and Air Service, Meier gave an update.

7.H Projects and Airport Capital Improvement Program Update

Project Manager, Singh gave an update.

7.I Financial Update

Assistant Airport Director, Carpenter provided an update.

7.J Future City council Update

Assistant Airport Director, Carpenter provided an update.

8. EXECUTIVE DIRECTOR REPORT

Executive Director of Aviation, Barrett provided updates.

9. COMMISSIONERS REQUESTS AND REPORTS

10. REPORT OF COUNCIL ACTIONS:

10.A Past City Council Actions

11. RECEIVE AND FILE:

11.A Airline Activity Report January 2026

11.B Airline Activity Report Fiscal Year Comparison

11.C Request For Proposal (RFP) and Invitation For Bid (IFB) Update

12. COMMITTEES:

12.A Future Committee Meetings

12.B Committee's Roster

13. ADJOURNMENT:

The Airport Commission adjourned at 6:31P.M. to the Regular Meeting on March 18, 2026, at 4:00 P.M.

Mariana Anguiano

Mariana Anguiano

Executive Administrative Assistant



AIRPORT COMMISSION STAFF REPORT

DATE: March 18, 2026

SUBJECT: RECOMMEND CONSTRUCTION CONTRACT NO. 26P038 FOR PARKING ACCESS AND REVENUE CONTROL SYSTEMS AND CONTRACT SERVICES AGREEMENT NO. 26P039 FOR A PREBOOKING AND RESERVATION SYSTEM WITH SKIDATA, INC., FOR PALM SPRINGS INTERNATIONAL AIRPORT

FROM: Edward Graff, Landside Operations Manager

BY: Department of Aviation

SUMMARY:

This action will recommend to the City Council to award Construction Agreement No. 26P038 for Parking Access and Revenue Control Systems (PARCS) for an amount not to exceed \$651,918 and Contract Services Agreement No. 26P039 for a Prebooking and Reservation System for an amount not to exceed \$43,780 with SKIDATA, Inc. for the Palm Springs International Airport (Airport).

RECOMMENDATION:

1. Recommend the approval of Construction Agreement No. 26P038 for Parking Access and Revenue Control Systems (PARCS) to the City Council for an amount not to exceed \$651,918 for an initial five-year term commencing on April 9, 2026, and continuing through April 8, 2031.
2. Recommend the approval of Contract Services Agreement No. 26P039 for a Prebooking and Reservation System to the City Council for an amount not to exceed \$43,780 for an initial five-year term commencing on April 9, 2026, and continuing through April 8, 2031.

BACKGROUND:

The Palm Springs International Airport seeks to enhance its Parking Access and Revenue Control System (PARCS). A Parking Access and Revenue Control System is a system designed to manage parking access, payment, and revenue collection for parking facilities. It automates the entry, exit, and payment processes, ensuring efficient management of parking operations. The Airport also seeks to implement an integrated Pre-Booking and Reservation System platform. A parking prebooking and reservation system is a digital platform that allows users to book parking spaces in advance. The system can be accessed from computers and mobile apps, providing real-time availability, booking options, and payment functionalities. These systems are crucial for enhancing the passenger experience, facilitating data-driven decision-making, and boosting non-aeronautical revenue.

The Airport consistently ranks among the fastest-growing airports in the U.S. In calendar year 2025, the Airport had approximately 3.31 million passengers, with over 1.65 million enplanements. Parking is a vital part of the Airport's ground access strategy and it's the second-largest source of non-airline revenue, generating over \$7 million annually from approximately 200,000 transactions from departing passengers, people parking to pick-up and drop-off passengers, Turo rental pick-ups, and Stay and Play guests. The average daily occupancy of the lot is 72% during the peak season, from October through May.

The Airport has four paid public parking lots; Parking Lots A, B, C, and D, that are open daily and provide a total of 880 parking spaces. Additionally, the Airport has an overflow parking lot that is opened for paid public parking when Parking Lots A through D have a remaining vacancy of 25 parking spaces. The overflow parking lot provides an additional 837 parking spaces.

For the last 26 years, the Airport has utilized contracted services to manage the Airport's parking access, revenue collection, and reporting. The Airport's current parking management company, ABM Aviation Inc., utilizes a SKIDATA Parking Access and Revenue Control System which is outdated, has reached the end of its useful life, and is creating operational challenges for the Airport.

Staff reached out to Ontario, Dallas Love Field, San Jose airports and various parking management companies, on what systems they have worked with and what worked and didn't work. SKIDATA, TIBA, and Amano were three most recommended systems.

STAFF ANALYSIS:

The Department of Aviation worked with the Procurement and Contracting Department to issue a formal Request for Proposals (RFP) process to identify a qualified contractor for the needed services. The RFP was advertised in the local newspaper and published on the PlanetBids procurement platform. By the submission deadline of December 15, 2025, the City received six (6) proposals. Following a preliminary administrative review, three (3) proposals were deemed non-responsive for failing to meet the mandatory submittal

requirements. The remaining three (3) responsive firms were:

- Skidata, Inc. – Phoenix, AZ
- IP Parking NA, Inc. – Sterling, VA
- TIBA Parking Systems LLC – Anaheim, CA

The evaluation team made up of City staff from the Aviation and Information Technology Departments and a representative from the McGhee Tyson Airport - Knoxville, evaluated the proposals received against published criteria that included the firm's experience, the staff experience, the understanding of the scope of work, local preference, price, and interviews.

SKIDATA, Inc. was ranked the highest by the evaluation team and is being recommended for award of the contract. SKIDATA is part of ASSA ABLOY, the global leader in access solutions. SKIDATA USA has become the largest parking solution provider in North America, with an installed base of over 1,000 systems. Their solutions are deployed in airports, municipalities, off-airport parking operations, shopping centers, office complexes, universities, and medical centers across North America.

SKIDATA systems manage parking spaces across multiple U.S. airport installations.

Examples include:

- San Diego International Airport – over 9,000 parking spaces
- San Jose International Airport– over 5,000 parking spaces
- Dallas Love Field Airport – over 50,000 parking spaces
- Raleigh-Durham International Airport – over 10,000 parking spaces

The new PARCS is designed to maximize operational efficiency, reduce capital expenditure, and support the airport's long-term strategic and financial objectives. It will also provide reliable, cost-efficient, and innovative parking solutions tailored to Palm Springs International Airport's operational needs, which includes the following:

Reuse and Refurbishment of Existing Parking Gates

Following an assessment of the Airport's existing entry gate infrastructure, SKIDATA proposed a cost-efficient approach to modernization. This strategy preserves valuable assets while delivering the performance and appearance of a newly deployed system by implementing the following:

- Reuse of existing gate mechanisms that remain structurally sound.
- Refurbishment using new LED Light Heads for advanced customer guidance. LED Light Heads are more efficient and durable, have better visibility, and longer lifespan.

License Plate Recognition (LPR) – The Ruby Camera

The Ruby Camera is a cutting-edge License Plate Reader System that enhances video surveillance with its 4K resolution. It is designed for high-tech surveillance and includes the following:

- High-accuracy license plate recognition optimized for fast-moving, free-flow, and gateless environments.
- Seamless integration with SKIDATA Mobility Suite for ticketless entry, frictionless exit, and virtual credentialing.
- Encrypted data transmission ensuring secure handling of plate images and transaction data.

Power.Gate Plus.

- Premium all-in-one entry/exit terminal with integrated ticketing, payment, and credentialing.
- Europay, MasterCard, and Visa-certified payment support, including insert, tap, and mobile wallet transactions.
- Bright, intuitive customer interface with touchscreen guidance and LED signaling.
- Secure, encrypted transaction processing via certified payment gateways.

Fully Cloud-Hosted PARCS Architecture

This cloud approach delivers a modern, future-ready foundation for the Airport's parking operations.

- Reduces operational complexity and long-term costs.
- Enhanced cybersecurity and centralized system management.
- Reduced IT overhead and lifecycle cost savings.

Pay-Per-Use Loyalty Program for Frequent Customers

SKIDATA will implement a Pay-Per-Use program to support frequent travelers and improve customer retention:

- Faster, frictionless entry and exit.
- Personalized offers and customer engagement tools.
- Enhanced traveler satisfaction and loyalty.

SKIDATA in partnership with Chantry, will integrate the Prebooking and Reservation System with PARCS. Chantry is the longest established specialist provider of airport parking reservation systems, supporting airports globally with digital prebooking, e-commerce, and yield management capabilities since 1991. For over three decades, Chantry has focused exclusively on the development, deployment, and continuous enhancement of digital airport parking solutions, enabling airports to grow non-

aeronautical revenue, improve customer experience, and gain greater operational visibility across their parking facilities. Chantry brings extensive experience within multi-vendor, prime-subcontractor project environments and has a track record of delivering fully integrated airport solutions in collaboration with PARCS delivery providers, operators, and Airport IT teams.

The proposed PARCS and Prebooking and Reservation Systems will maximize operational efficiency, reduce capital expenditures, and support the Airport's long-term strategic and financial objectives by delivering reliable, cost-efficient, and innovative parking solutions tailored to the Airport's needs while enhancing the customer experience through more efficient, less stressful parking and user-friendly payment options.

ALIGNMENT WITH STRATEGIC PLANNING:

Approval of this action supports the City of Palm Springs' Strategic Plan Broad Goals of Infrastructure and Facilities, and it also supports the Airport's 2025-2029 Strategic Plan's Strategic Priorities for Operational Excellence and Infrastructure.

FISCAL IMPACT:

Sufficient funding is budgeted in Fiscal Year 2025-26 in the Department of Aviation, Airport Capital Projects, Other Equipment Account 4167065-60015.

ATTACHMENTS:

The attachments for Construction Agreement No. 26P038 and Contract Services Agreement No. 26P039 are pending completion by the Procurement Department. Agreements will be provided in the staff report to the City Council for the April 8, 2026 meeting.

SKIDATA

ASSA ABLOY

WELCOME TO PALM SPRINGS

BAGGAGE CLAIM
GROUND TRANSPORT

ELEVATOR
BAGGAGE CLAIM
GROUND TRANSPORT

Palm Springs International Airport (PSP)

Parking Access and Revenue Control System (PARCS) – RFP 15-25

AGENDA

we
change
the world of
welcoming
people

- SKIDATA an ASSA ABLOY company
- Hardware Modernization
- License Plate Recognition
- Mobility Suite as a Service
- Scan-to-Pay
- Reservations
- Contract Parker
- Pay-per-Use & Loyalty
- Q & A

Proud Member of the ASSA ABLOY Family

Since 2024, SKIDATA is a proud member of ASSA ABLOY. This partnership enhances our reach & innovation capabilities while maintaining our unique identity and commitment to quality.

- **Expanded Reach:** Leveraging ASSA ABLOY's global presence to access new markets.
- **Enhanced Innovation:** Pooling expertise to drive technological advancements.
- **Continued Independence:** Operating as a distinct business, preserving our brand and operational autonomy.

Together, we are set to redefine access solutions, providing secure, efficient, and reliable services worldwide.



Form Follows Function



Ruby LPR



Power.Gate Plus

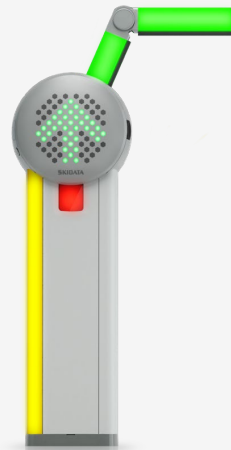

Barrier.Gate

Power.Gate Plus



Public

© SKIDATA | Company Confidential

11

Features:

- 15" Touch display
- Compatible with previous models
- Improved User Guidance
- Supports Pay On Entry
- Supports Dynamic Rates
- Supports Advertising & Branding

User Interfaces:

- Screen Ticket Button
- RFID-Hotspot
- QR-Scanner
- EMV & NFC Payments
- Screen Intercom Button

Investment security built to grow with your operation.

Power.Gate Plus

- **Premium all-in-one entry/exit terminal with integrated ticketing, payment, and credentialing**
- EMV-certified payment support including insert, tap, and mobile wallet transactions
- Modular hardware design enabling easy upgrades, add-ons, and future-proof expansion
- **High-speed thermal ticket printing for reliable, low-maintenance operation**
- Robust outdoor-rated construction built for high-volume, 24/7 environments
- **Bright, intuitive customer interface with touchscreen guidance and LED signaling**
- Secure, encrypted transaction processing via certified payment gateways
- **Full integration with SKIDATA Mobility Suite for centralized monitoring, reporting, and remote management**



More Than Just A Barrier

- **Intellegent & Efficient**

- Color-coded LED illuminated status indication – User guidance in-the-lane
- Barrier arm break-off alert – no tool reset
- Configurable opening speeds starting at 1.5 seconds/cycle
- Direct drive (low maintenance/low energy consumption/high speed)
- ADA Folding Arm and Straight Arm options
- Optional lighted gate arms - internal RGB LEDs for dynamic status indication

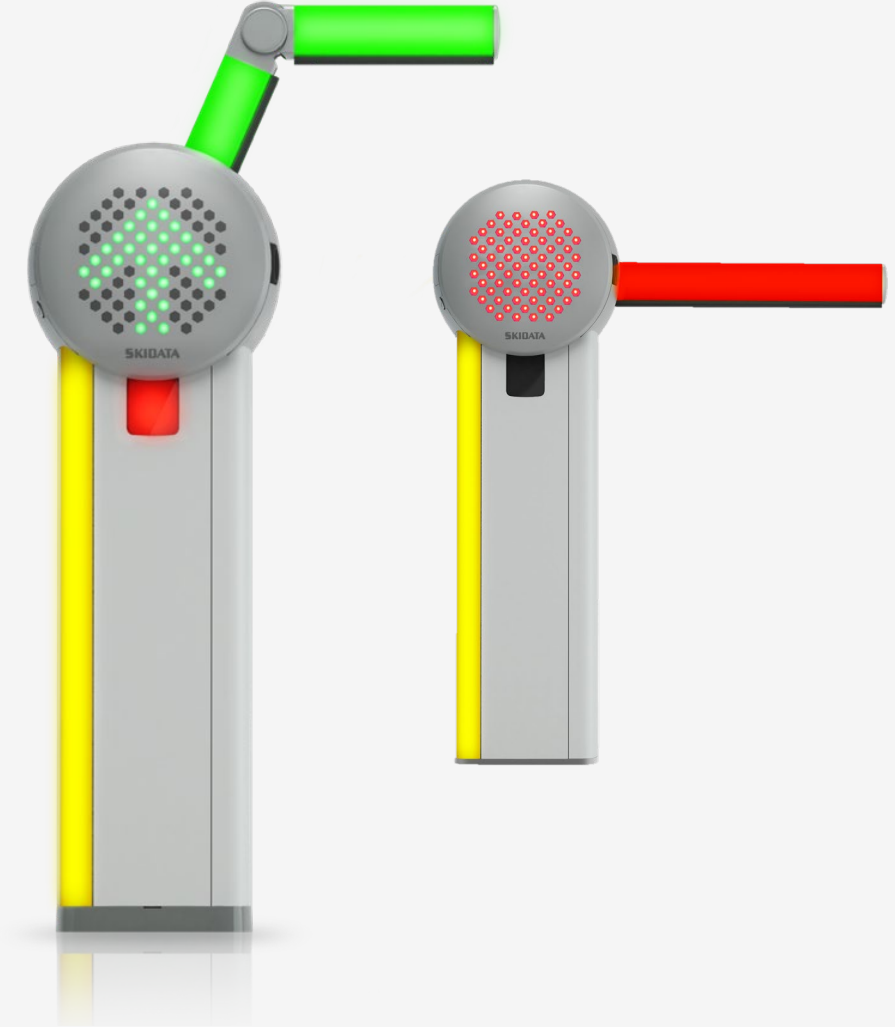
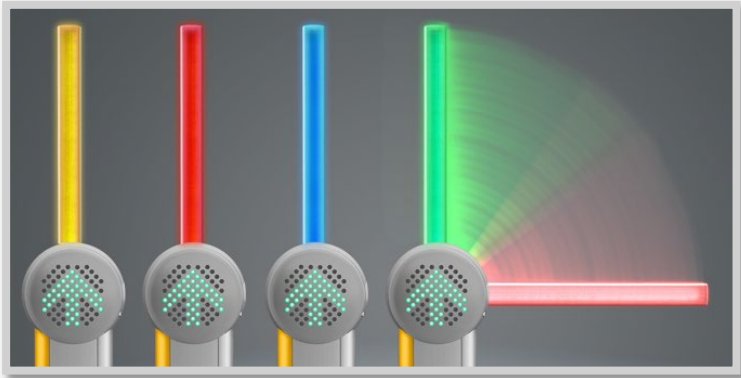

License Plate Recognition (LPR) – The Ruby Camera

- High-accuracy license plate recognition optimized for fast-moving, free-flow, and gateless environments
- Dual-capture imaging (overview + plate crop) for superior verification and audit reliability
- Edge-based processing for rapid reads and minimal latency in high-volume lanes
- Seamless integration with SKIDATA Mobility Suite for ticketless entry, frictionless exit, and virtual credentialing**
- Supports virtual triggering, eliminating the need for in-ground loops or major civil work**
- Robust performance in all lighting and weather conditions, including glare, rain, and nighttime operation
- Compact, modern housing designed for easy mounting on poles, gantries, or lane structures**
- Encrypted data transmission ensuring secure handling of plate images and transaction data
- Scalable architecture allowing additional cameras to be added without system redesign



Move to the Cloud

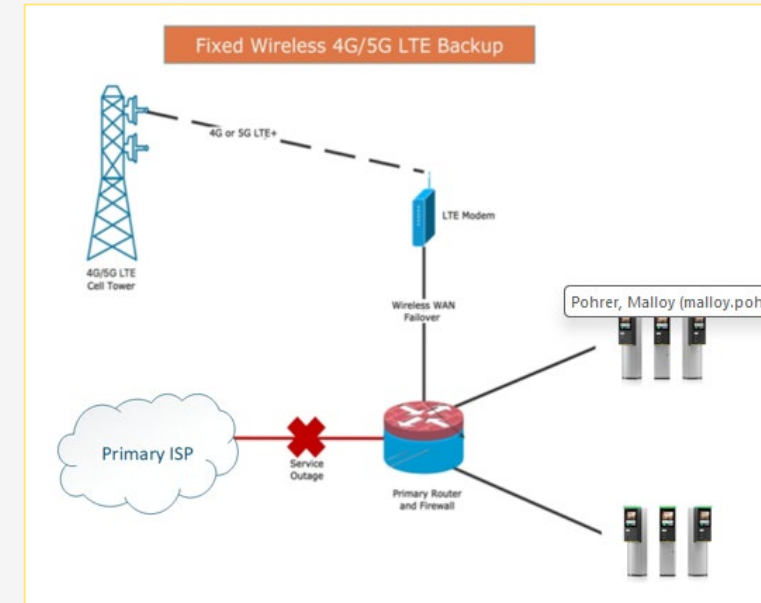
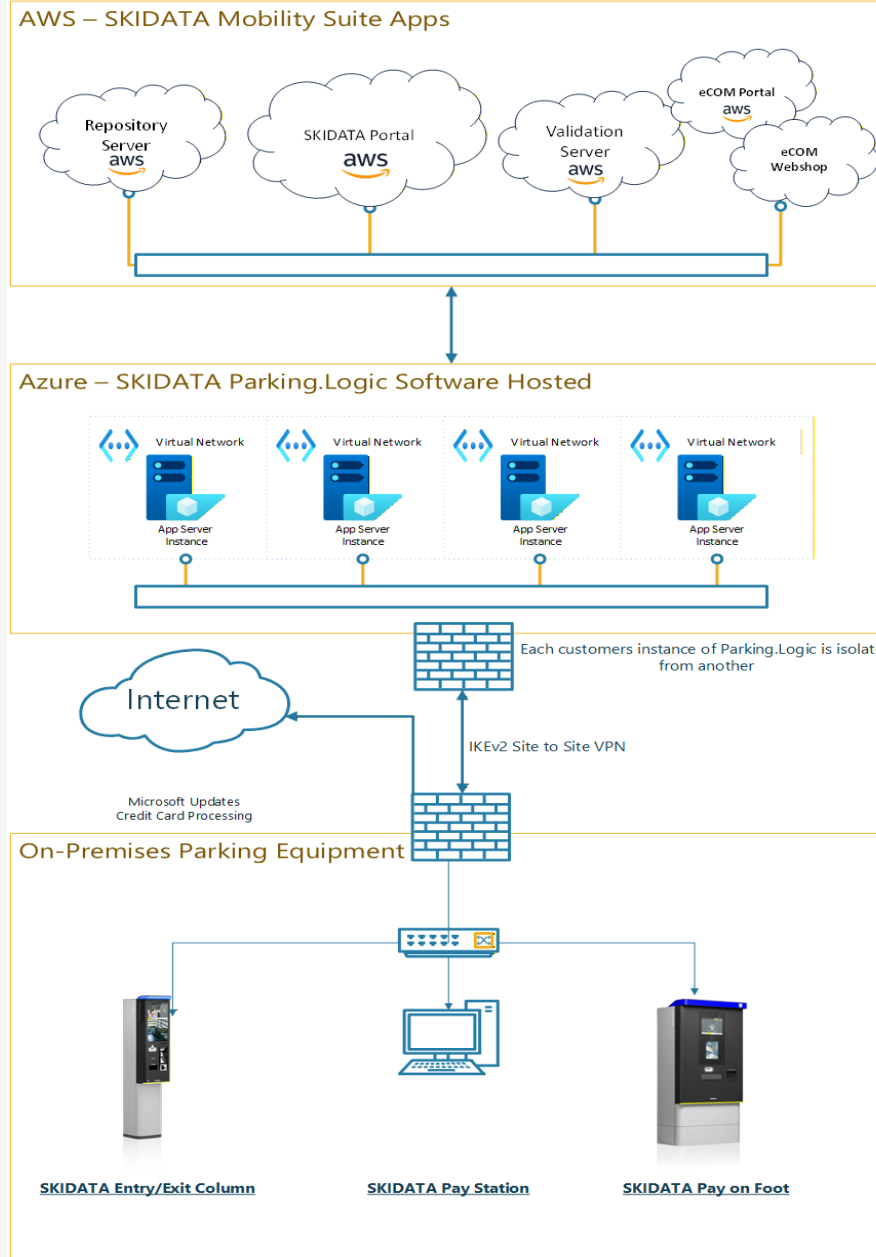

Mobility Suite – Remote Monitoring & Control



Scan-to-Pay | Mobile Payment Option

Payment made easy and convenient

- Convenient mobile payment options without registration
- Increase revenue with sales of parking products and advertisement opportunities
- Raise your operational efficiency with remote handling of customer service



No App needed. No Queuing. No touch.



Scan-to-Pay | Mobile Payment Option

SCAN TICKET

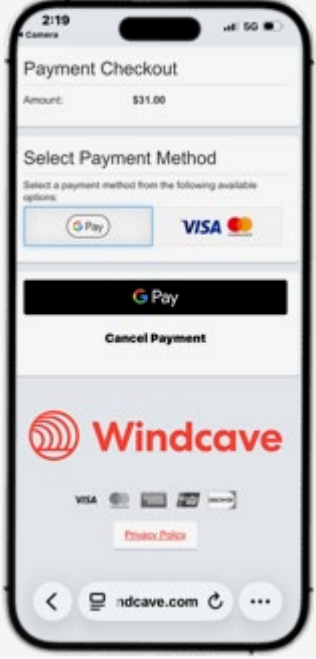
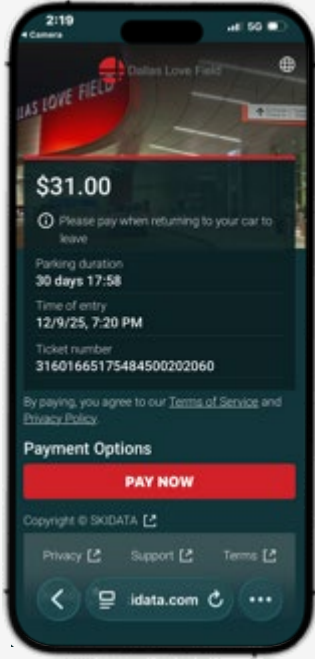
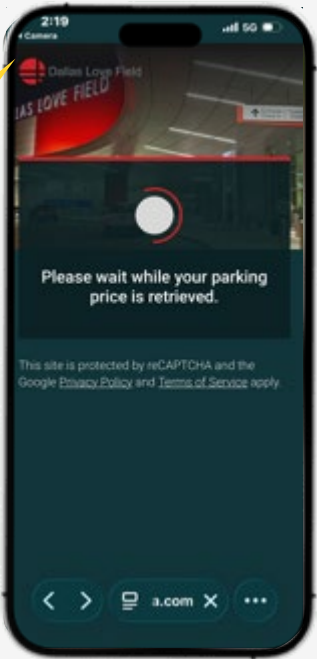
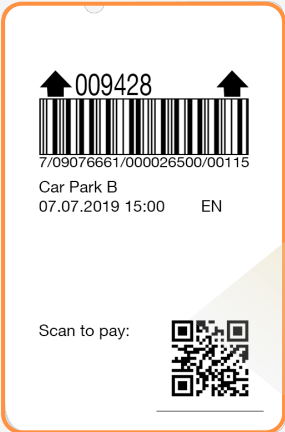

No App needed. No Queuing.

Reservations – Promotions and Discounts

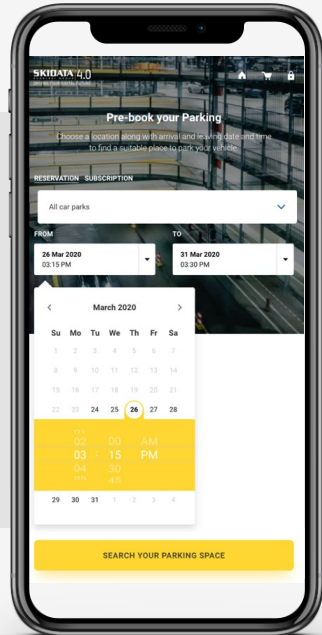

Select **Location**, select **Date** and search availability
Use **Promo Code** for discounts

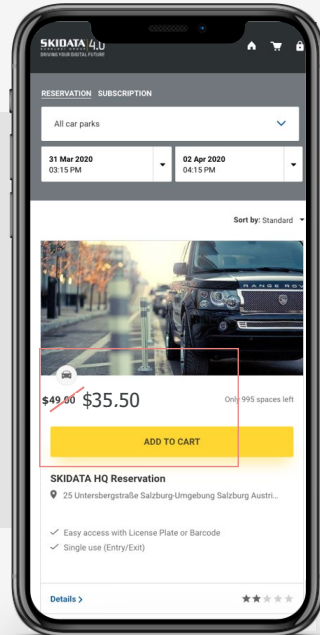

Select **Reservation Product**

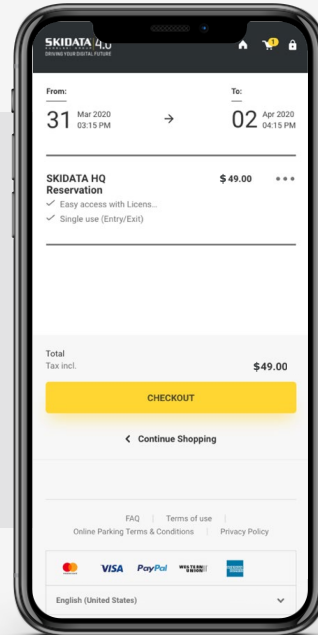

Verify **Shopping Cart** and select **Payment** option

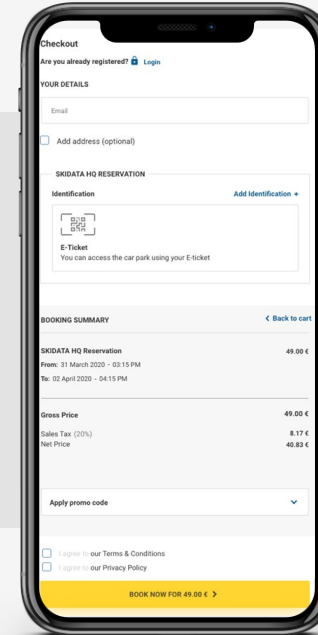

Checkout and book **Reservation**
- Add **License Plate** for EZ Entry

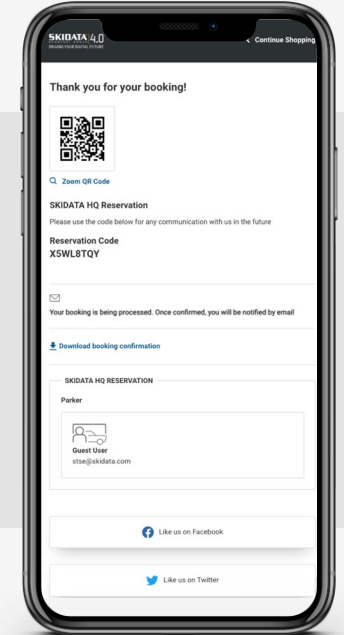

Receive **Confirmation** and **Receipt**
Use **QR** Code or **LP**

Contract Parker – SELF Management Portal

Select subscription product – book it – use it

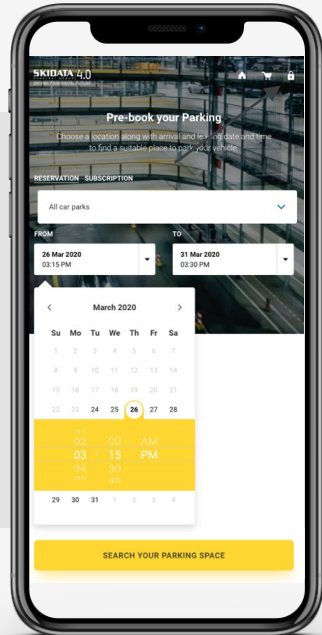

Sign In or Register

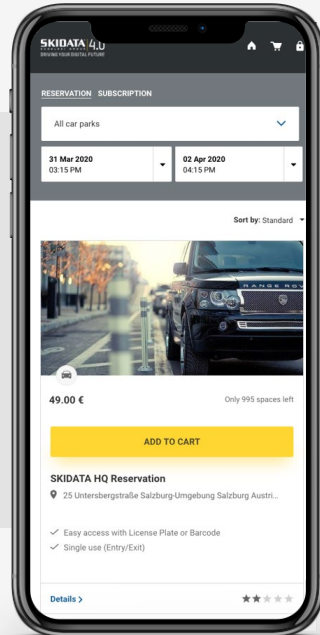

Select **Contract** products can be **Whitelisted** to remove visibility from general public

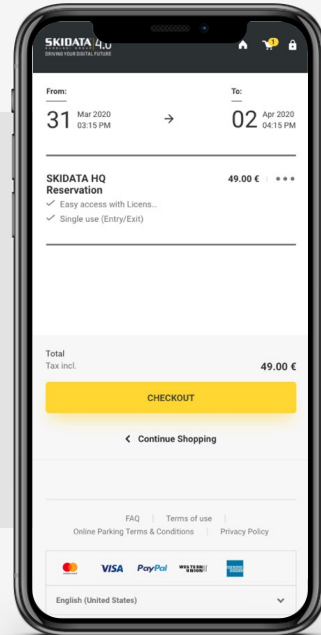

Verify **Shopping Cart** and select **Payment** option

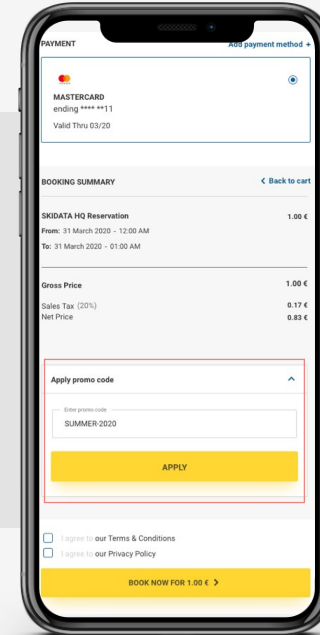

Continue to **Checkout** -existing customer data, preferred payment, and access identification associated with **Sign In**

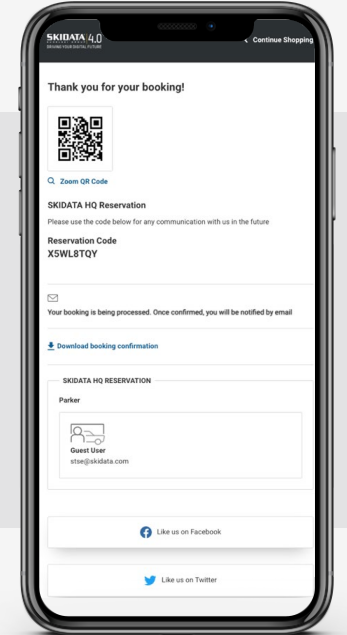

Receive **Confirmation** and **Receipt**

Use **QR Code** or **LP**

Pay-Per-Use Frequent Parker Portal

Register – CC on file – charged after each stay (Loyalty Discount)

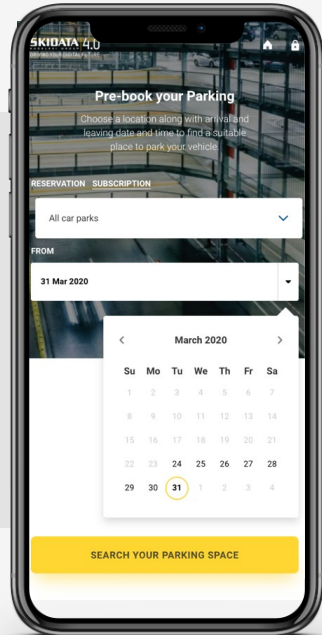

Open **Frequent Parker** portal

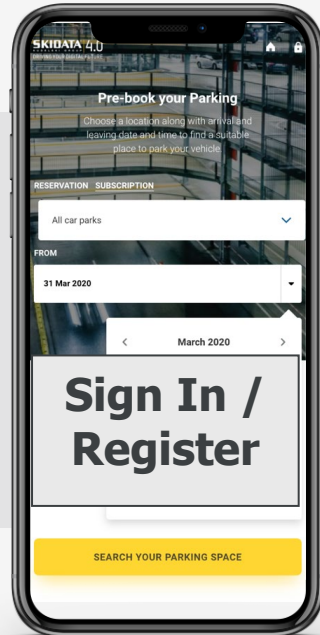

Sign In or **Register**

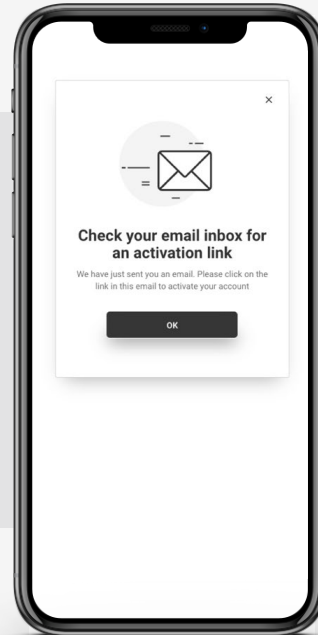

Receive **Activation** link

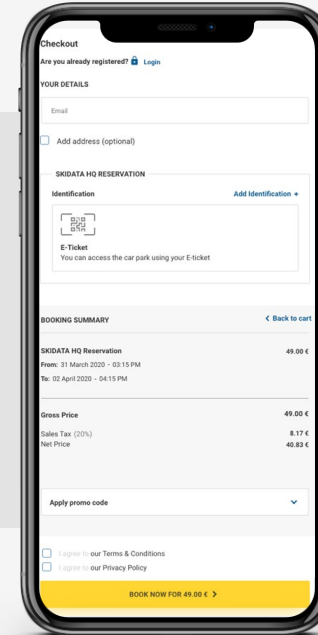

Complete **Profile** setup with **License Plate** and **Credit Card** information

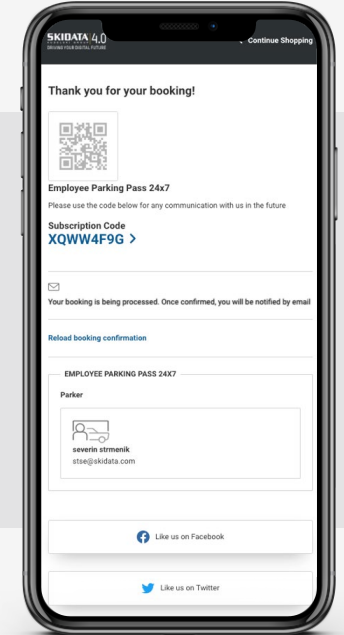

Drive in - Drive out!
-see all transactions and charges online via **Frequent Parker** portal

A couple is captured in mid-air, jumping joyfully on a grassy mountain peak. The man on the left is wearing a bright yellow jacket and a dark backpack, while the woman on the right is wearing a dark jacket and a yellow backpack. They are holding hands, and their arms are raised in celebration. The background features a vast, hazy mountain range under a bright blue sky with scattered white clouds. The overall mood is one of freedom and achievement.

SKIDATA
ASSA ABLOY

Thank you

skidata.com

DISCLAIMER

The information presented in this document is for informational purposes only and may contain technical inaccuracies, omissions and typographical errors.

The information contained herein is subject to change and may be rendered inaccurate for many reasons, including but not limited to product and roadmap changes, hardware changes, software changes, component changes, or the like. SKIDATA assumes no obligation to update or otherwise correct or revise this information. However, SKIDATA reserves the right to revise this information and to make changes from time to time to the content hereof without obligation of SKIDATA to notify any person of such revisions or changes. Technical data subject to change without notice.

SKIDATA MAKES NO REPRESENTATIONS OR WARRANTIES WITH RESPECT TO THE CONTENTS HEREOF AND ASSUMES NO RESPONSIBILITY FOR ANY INACCURACIES, ERRORS OR OMISSIONS THAT MAY APPEAR IN THIS INFORMATION.

SKIDATA SPECIFICALLY DISCLAIMS ANY IMPLIED WARRANTIES OF MERCHANTABILITY OR FITNESS FOR ANY PARTICULAR PURPOSE. IN NO EVENT WILL SKIDATA BE LIABLE TO ANY PERSON FOR ANY DIRECT, INDIRECT, SPECIAL OR OTHER CONSEQUENTIAL DAMAGES ARISING FROM THE USE OF ANY INFORMATION CONTAINED HEREIN, EVEN IF SKIDATA IS EXPRESSLY ADVISED OF THE POSSIBILITY OF SUCH DAMAGES.

SKIDATA® is a registered trademark of SKIDATA GmbH in the U.S.A., the European Union and other countries. © ASSA ABLOY



PSP Strategic Plan Update

2025-2026 Progress

Jason Hodges
Strategy and Innovation Administrator



palm springs
INTERNATIONAL AIRPORT

Why PSP Created the Strategic Plan



Palm Springs International Airport has experienced sustained passenger growth and increasing operational complexity.

To guide the airport's future, the Airport Commission and executive leadership collaborated to develop the [PSP Strategic Plan](#), establishing a clear five year direction for the airport.

The plan ensures that operational decisions, investments, and partnerships remain aligned with PSP's long term goals while supporting the Airport Master Plan.



Vision

An iconic airport passionately connecting
Greater Palm Springs to the world

Mission

Moving you with unforgettable hospitality

Values



Passion



Responsibility



Integrity



Diversity



Exceptionalism







Priorities and Initiatives



People and Culture



-  Expanding aviation career awareness through student engagement and internship opportunities
-  Strengthening employee engagement through our annual team member engagement survey and feedback tools
-  Supporting professional development and leadership growth for PSP staff
-  Strengthening service culture and connection throughout the PSP community



Operational Excellence



Safety and Security

- FAA approved SMS manual
- Security screening upgrades
- Security plan update

Guest Experience Improvements

- PSP GX plan implementation
- Airport Art Program adoption and plan

Operational and Technology Enhancements

- New PARCS selected
- CLEAR eGate installed

Partnerships



- Strengthening collaboration with airport tenants through regular coordination meetings
- Improving transparency through the Progress PSP project update platform
- Communicating PSP's regional economic impact and value to the Coachella Valley
- Expanding outreach with local businesses and community leaders across the Valley



PALM SPRINGS INTERNATIONAL AIRPORT ECONOMIC IMPACT

A new economic impact study confirms the vital role PSP plays as a powerful economic engine for our region — supporting thousands of jobs, generating billions in local economic activity, and delivering hundreds of millions in tax revenue to the Coachella Valley and beyond.

\$ 2.5B+
Total Economic Impact (FY2024)

BY THE NUMBERS • FY2024 Economic Impact

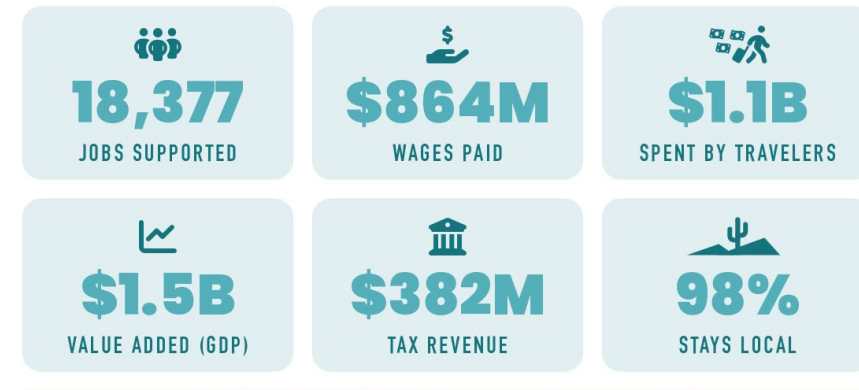

Infrastructure



- Advancing infrastructure planning aligned with the Airport Master Plan
- Expansion of the new Baggage Handling System facility



- Runway analysis completed and under review
- Escalator replacement and breach gate improvements underway



- Bono and Courtyard restroom redesign completed
- Landside shade structure project moving forward

Sustainability



- Expanding PSP's electric vehicle fleet for maintenance operations
- Installing 80 Level 2 EV chargers in the public parking lot
- Supporting alternative commuting through IE Commuter incentives for PSP employees
- Partnering with airport tenants on their sustainability initiatives



Q & A

**CITY OF PALM SPRINGS
PALM SPRINGS INTERNATIONAL AIRPORT**

Financial Summary
Ending February 28, 2026

Fund 405 - Customer Facility Charges	FY 25-26 Forecasted Budget	FY 25-26 YTD Actual	FY25-26 % Of Budget	FY 24-25 YTD Actual	FY 24-25 vs FY 25-26 % Change
Operating Revenue	9,765,131	4,514,205	46%	4,455,011	1%
Operating Expenditures	2,223,681	68,138	3%	-	0%
Surplus / (Deficit)	7,541,450	4,446,067	59%	4,455,011	0%

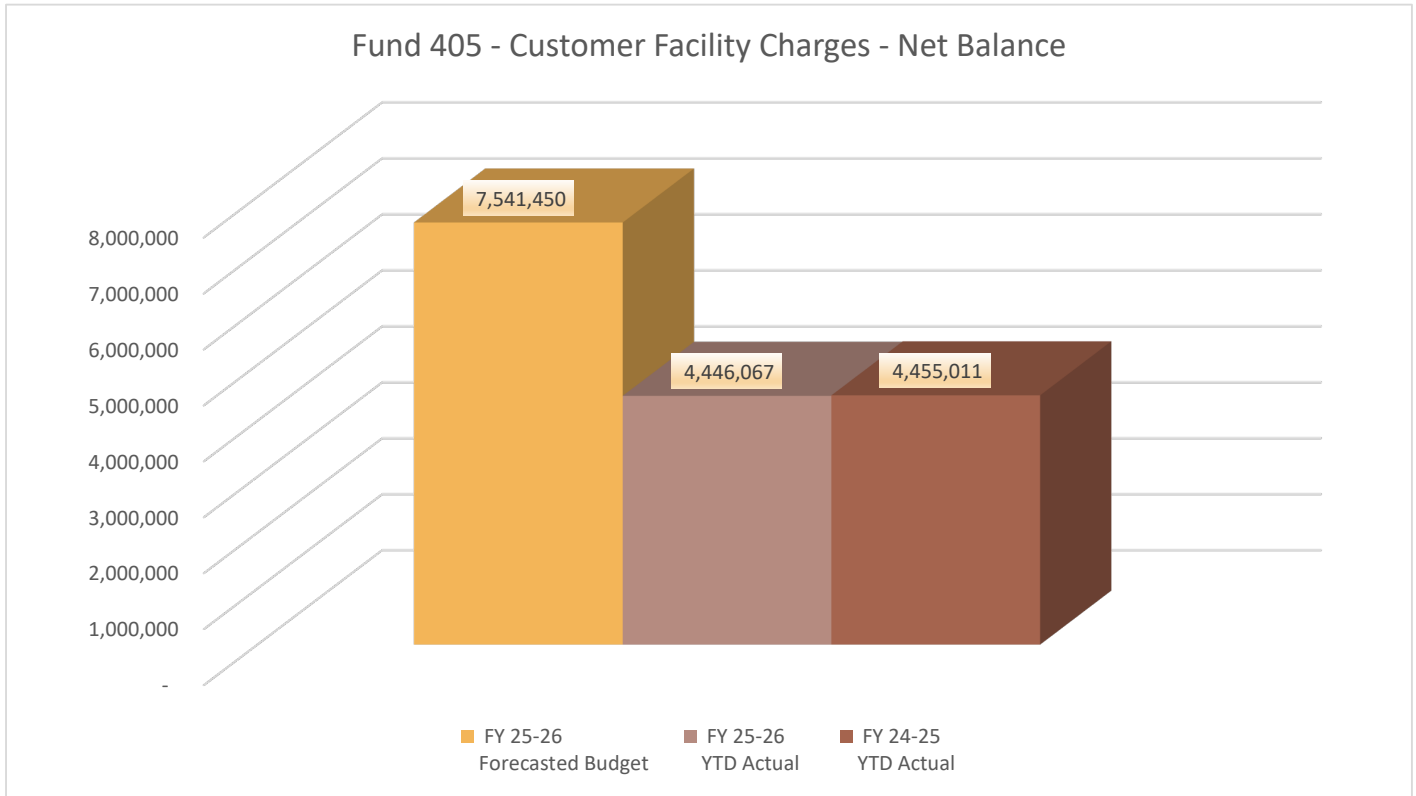

Fund 405 is the airports fund for customer facility charges (CFC).

Revenues

CFC revenue is collected by the car rental concessionaires and remitted to the Airport according to state law to support the future consolidated rental car facility project. In March 2022, City Council approved a change in the collection methodology rate from \$10 per transaction to \$9 per day up to five days maximum.

YTD, revenues of \$4,514,205 represents 46% of the full year budget, reflecting seasonal nature of CFC revenues.

Expenditures

YTD, expenditures of \$68,138 represents 3% of the full year budgeted expenditures.

**CITY OF PALM SPRINGS
PALM SPRINGS INTERNATIONAL AIRPORT**

Financial Summary
Ending February 28, 2026

Fund 410 - Passenger Facility Charges	FY 25-26 Forecasted Budget	FY 25-26 YTD Actual	FY25-26 % Of Budget	FY 24-25 YTD Actual	FY 24-25 vs FY 25-26 % Change
Operating Revenue	6,823,575	3,690,109	54%	3,709,951	-1%
Operating Expenditures	2,619,113	267,033	10%	306,337	-13%
Surplus / (Deficit)	4,204,462	3,423,076	81%	3,403,614	1%

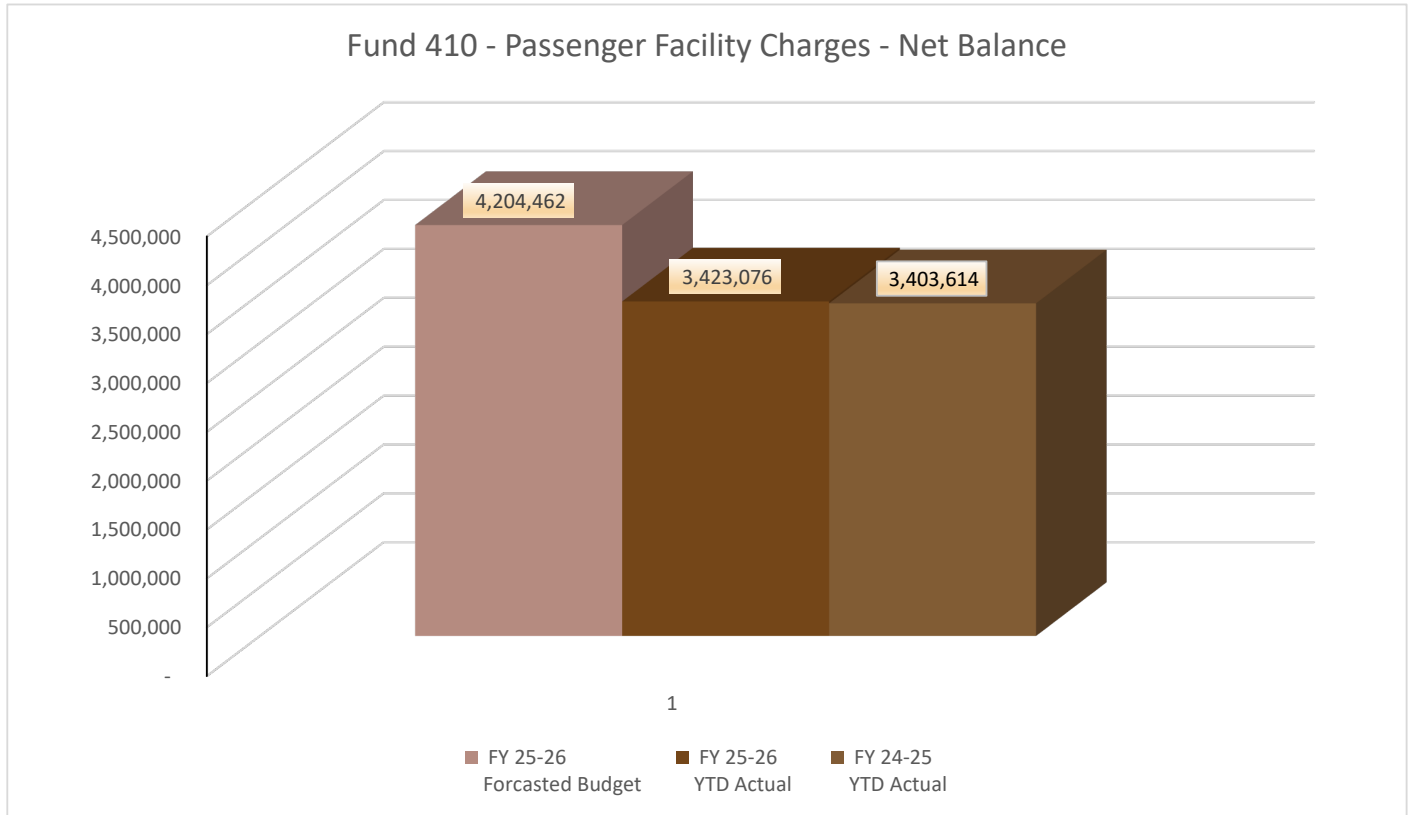

Fund 410 is the airports fund for passenger facility charges (PFC).

Revenues

The PFC, provides a source of additional capital to improve, expand, and repair the nation’s airport infrastructure. The FAA must approve any facility charges imposed on enplaning passengers. The PFC at PSP is \$4.50 and the maximum PFC charge on any one passenger travel ticket is capped at \$18.00.

YTD, revenues of \$3,690,109 represents 54% of the full year budget, reflecting seasonal nature of PFC revenues.

Expenditures

On July 18, 2019, the City of Palm Springs issued 2019 Airport Passenger Facility Charge Revenue Bonds for \$22,270,000 to finance a portion of the design, acquisition, and construction of ticketing hall and baggage handling system improvements. Interest is payable semiannually on June 1, and December 1 of each year, commencing December 1, 2019, until maturity or earlier redemption. FY 25-26 principal is \$1,865,000 and interest is \$633,750. Expenses to fund 410 include principal and interest and contractual services to the bond consultant.

The expense decrease for FY2026 reflects the reversal of FY2025 Loan Interest accruals.

CITY OF PALM SPRINGS
PALM SPRINGS INTERNATIONAL AIRPORT
 Financial Summary
 Ending February 28, 2026

Fund 415 - Airport Operations & Maintenance	FY 25-26 Forecasted Budget	FY 25-26 YTD Actual	FY25-26 % Of Budget	FY 24-25 YTD Actual	FY 24-25 vs FY 25-26 % Change
Operating Revenue	54,538,758	34,676,416	64%	30,197,291	15%
Operating Expenditures	62,667,690	33,096,131	53%	32,803,290	1%
Surplus / Deficit	(8,128,932)	1,580,285	-19%	(2,605,999)	-161%

Fund 415 is the airports operation & maintenance fund which records for all the revenues and expenditures.

Revenues

Airport revenues included operating and non-operating revenues from airlines, fuel fees, terminal rentals, ground rentals, concessions, fines, parking, ground transportation, grant reimbursements, admission fees for the Palm Springs Air Museum and interest income.

Expenditures

Airport expenditures consist of personnel, contractual services, safety and security (Aircraft Rescue and Fire Fighting (ARFF) and law enforcement), utilities, maintenance, supplies, operating equipment, insurance, employee development, equipment rentals and repairs.

CITY OF PALM SPRINGS
PALM SPRINGS INTERNATIONAL AIRPORT
Financial Summary
Ending February 28, 2026

Fund 415 - Airport Operations & Maintenance	FY 25-26 Forecasted Budget	FY 25-26 YTD Actual	FY25-26 % Of Budget	FY 24-25 YTD Actual	FY 24-25 vs FY 25-26 % Change
Operating Revenue					
Airline Revenue					
Landing Fees	6,994,958	4,023,335	58%	3,920,250	3%
Terminal Airline Space/Joint Use	6,851,243	6,065,263	89%	4,432,646	37%
Gate Per Use Fees	2,265,677	1,689,691	75%	1,336,473	26%
Passenger Loading Bridge Fee	580,091	554,728	96%	280,082	98%
Baggage Handling System Fees	573,558	620,737	108%	245,711	153%
Total Airline Revenues	17,265,527	12,953,754	75%	10,215,162	27%
Non-Airline Revenue					
General Aviation	527,400	246,110	47%	220,010	12%
Non-Aeronautical Ground Rental	670,980	379,363	57%	442,734	-14%
Aeronautical Ground Rental	1,372,284	995,599	73%	876,644	14%
Parking	6,332,898	4,410,064	70%	3,995,061	10%
Airport Use Permits	120,000	96,418	80%	89,769	7%
Non-Airline Terminal Rent Fee	1,045,281	936,562	90%	741,090	26%
Non-Airline Term Rent Fee F&B	1,769,472	920,283	52%	766,394	20%
Non-Airline Term Rent Fee Retail	2,394,660	779,603	33%	899,202	-13%
Rental Car - Overflow Parking	368,085	109,756	30%	91,366	20%
Advertising	904,305	439,776	49%	419,693	5%
On Airport Rental Car	14,665,829	8,557,852	58%	8,089,008	6%
Commercial Services Fees	1,385,796	716,187	52%	714,905	0%
Ground Transportation Fees	2,147,531	1,067,053	50%	774,685	38%
Customs	448,233	234,361	52%	218,590	7%
All Other Revenue	3,120,476	1,833,676	59%	1,642,980	12%
Total Non-Airline Revenue	37,273,231	21,722,662	58%	19,982,129	9%
Total Operating Revenues	54,538,758	34,676,416	64%	30,197,291	15%

Airline Revenue all showed performance, collectively contributing to a 27% increase in total airline revenues over the prior year. Due to the implementation of Rates and Charges for FY2026.

Non-Airline Revenue grew by 9% over the prior year.

Non-Aeronautical Ground Rental declines 14% compared to FY24-25 primarily attributed to planned vacancy within the Accelerator Campus, the site was reallocated for aeronautical-related activities and City use.

Non-Airline Term Rent Fee Retail declines 13% compared to FY24-25 driven by a WHSmith reconciliation adjustment. The variance includes the application of their January payment.

CITY OF PALM SPRINGS
PALM SPRINGS INTERNATIONAL AIRPORT
Financial Summary
Ending February 28, 2026

Fund 415 - Airport Operations & Maintenance	FY 25-26 Forecasted Budget	FY 25-26 YTD Actual	FY25-26 % Of Budget	FY 24-25 YTD Actual	FY 24-25 vs FY 25-26 % Change
Operating Expenditures					
Airport Administration	12,463,697	4,637,686	37%	4,295,075	8%
Airport Information Technology	1,804,669	730,738	40%	665,753	10%
Airport Law Enforcement	3,725,167	2,215,369	59%	2,274,340	-3%
Aviation Security	1,931,063	1,005,377	52%	449,323	124%
Airside Operations	3,818,983	4,018,944	105%	4,000,684	0%
Airport Rescue - Fire	6,000,498	3,583,811	60%	3,169,961	13%
Landside Operations	1,712,282	2,063,918	121%	1,530,757	35%
Grounds Maintenance	1,009,028	394,866	39%	284,146	39%
Terminal Building Operations	12,878,740	6,425,790	50%	5,040,886	27%
Passenger Boarding Bridges	99,710	43,058	43%	15,753	173%
Baggage Handling System	1,109,939	569,727	51%	302,277	88%
Control Center Operations	5,989,139	2,640,373	44%	3,218,638	-18%
U.S. Customs	516,487	173,498	34%	159,938	8%
Planning & Projects	1,709,991	643,830	38%	136,530	372%
Budget Transfer Out	7,898,295	3,949,148	50%	7,244,000	-45%
Total Operating Expenditures	62,667,690	33,096,131	53%	32,788,061	1%
Surplus / (Deficit)	(8,128,932)	1,580,285	-19%	(2,590,770)	-161%

Aviation Security Increased primarily due to Salaries, Benefits and Security expenses have been allocated for FY2026.

Passenger Boarding Bridges Increase Contracts and Material and Supplies due to repairs and maintenance required.

Planning & Projects Increased due to Salaries and Benefits for new employees allocated. Funding for Contractual Services has been allocated in FY2026.

Control Center Operations decreased by 18%, primarily due to the reallocation of salaries and benefits to the Aviation Security department.

Year-to-date, the Airport has allocated 47% of its budget to Salaries & Benefits, 21% to Contractual Services, 10% to Utilities, 4% to Materials & Supplies, 1% to Insurance and 17% to Other City Services

CITY OF PALM SPRINGS
PALM SPRINGS INTERNATIONAL AIRPORT
 Financial Summary
 Ending February 28, 2026

Fund 416 - Airport Capital Projects	FY 25-26 Forecasted Budget	FY 25-26 YTD Actual	FY25-26 % Of Budget	FY 24-25 YTD Actual	FY 24-25 vs FY 25-26 % Change
Operating Revenue	37,051,071	4,124,814	11%	10,169,304	0%
Operating Expenditures	57,381,125	3,863,252	7%	8,398,458	-54%
Surplus / (Deficit)	(20,330,054)	261,562	-1%	1,770,846	-85%

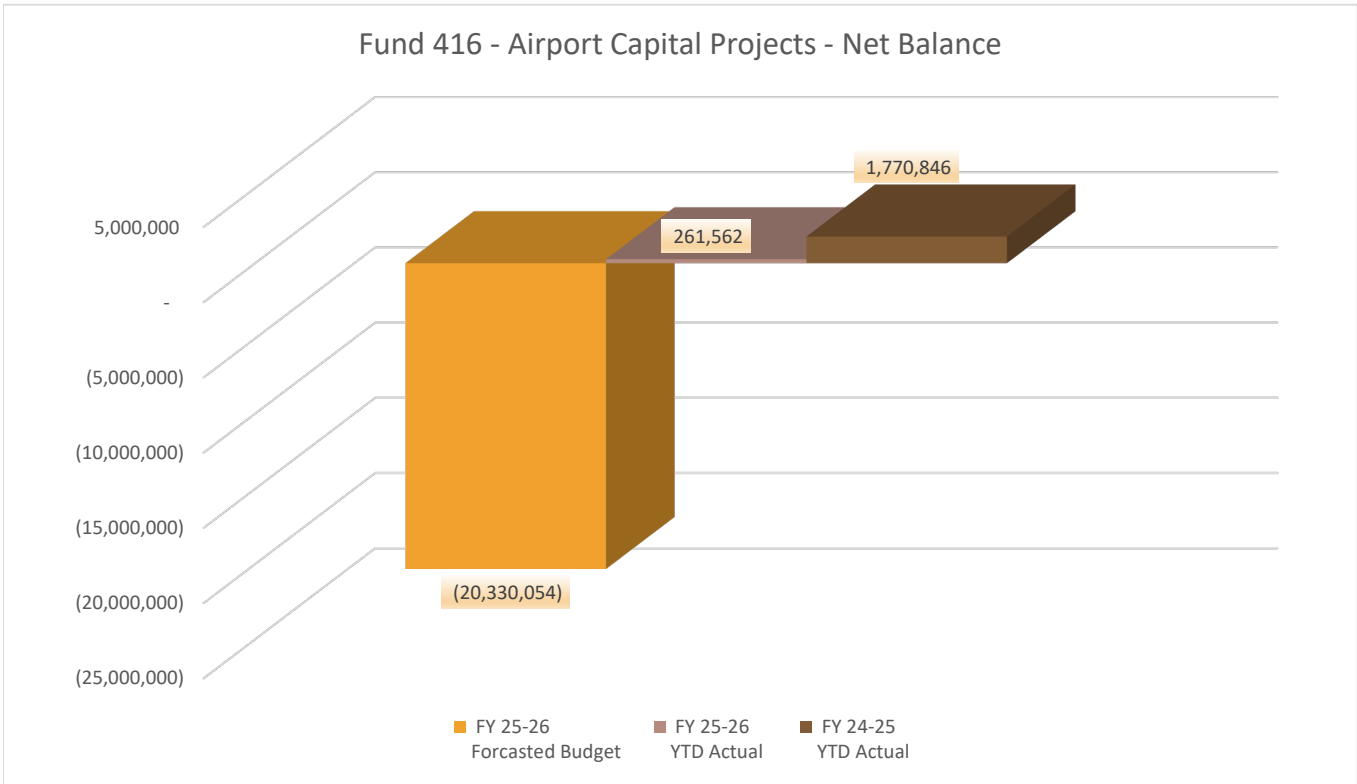

Fund 416 is the Airport Capital Program

Revenues

Airport Improvement Program (AIP) grants are offered to PSP to provide funding assistance for eligible capital projects that meet the criteria of the federal program. Additional funding is being distributed through AIP grant program by the Bipartisan Infrastructure Law (BIL). These grants have a 9.34% local share and the remaining 90.66% are reimbursed by the FAA. Revenues in excess of the Airport Operations & Maintenance are transferred to fund 416 to cover capital projects.

CITY OF PALM SPRINGS
PALM SPRINGS INTERNATIONAL AIRPORT
 Financial Summary
 Ending February 28, 2026

<u>Cash Summary</u>	FY 25-26 YTD Actual	FY 24-25 YTD Actual
Fund 405	64,527,953	58,116,723
Fund 410	2,767,763	1,905,024
Fund 415	56,441,109	61,308,527
Fund 416	5,208,816	5,309,159

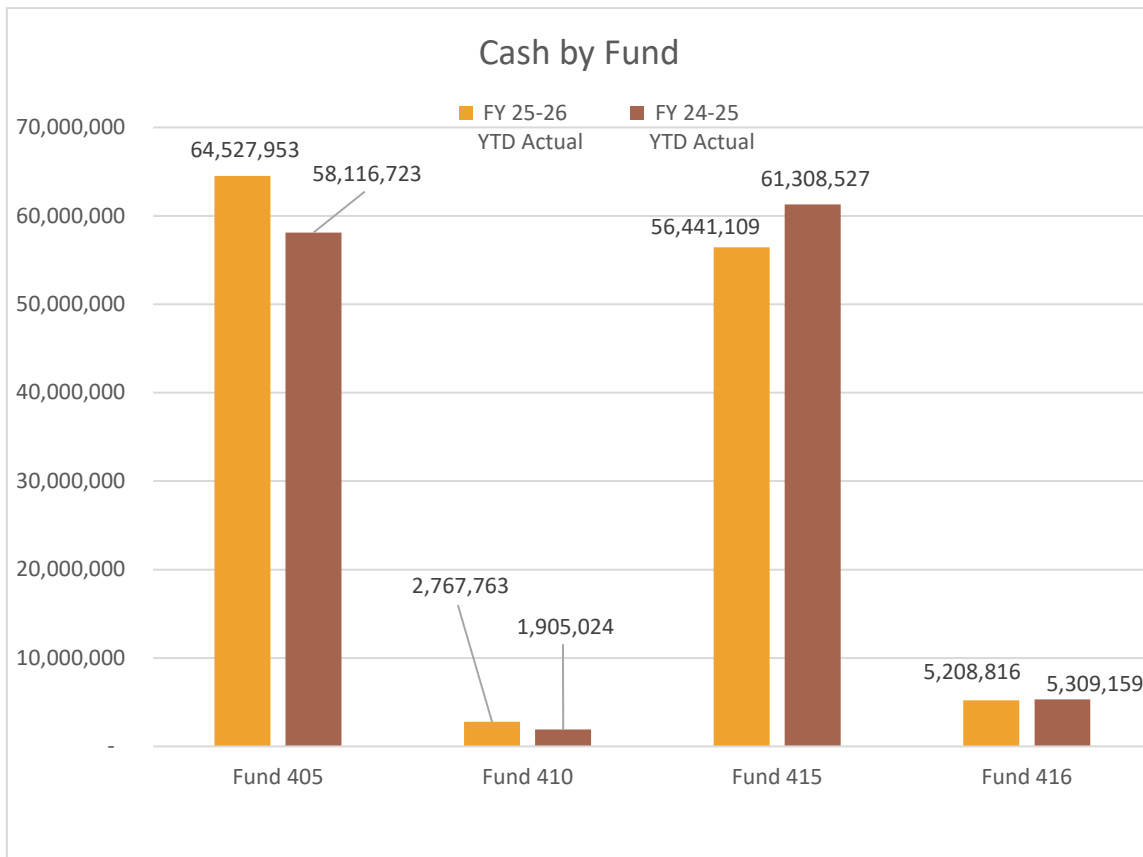



A Department of the City of Palm Springs

Palm Springs International Airport
3400 E. Tahquitz Canyon Way, Suite 1
Palm Springs, CA 92262-6966

flypsp.com
T: (760) 318-3800

DATE: March 10, 2026
TO: Chairman Corcoran and Airport Commissioners
FROM: Harman Singh, Project Manager
SUBJECT: Projects and Airport Capital Improvement Update

Capital Projects

Bono Concourse Escalators:

Background: This project aims to replace the escalators leading to the Sonny Bono Concourse to reduce noise and improve operational uptime. Both Sonny Bono Concourse escalators were refurbished with in-truss replacements 9 years ago. At the request of the Airport Commission, the Executive Director of Aviation has directed Airport staff to research the costs and efforts required for a full replacement.

Status: In Progress

- Project Design & Finished (D&F) letter has been reviewed and approved by the airport staff.
- The project is in queue for production.

Next Steps:

- Escalator equipment manufacturing and delivery of material.

Timeline:

- Staff will provide manufacturing timeline once staff receive concrete dates from the vendor.

Taxicab/Transportation Network Company (TNC) Shade Structures - Measure J Funds:

Background: This project is one of the four capital improvement projects funded through Measure J. The project involves the design and installation of dedicated shade structures in the pick-up area for Taxicab services and TNC's, specifically Uber Technologies Inc. and Lyft Inc. The goal is to enhance passenger comfort and safety by providing protection from the elements, thereby contributing to a more positive transportation experience.

Status: In Progress

- During September 15, 2025, Commission meeting, Executive Director presented Measure J & Measure D staff recommendations, and three proposals were presented to the Commission. Commission advised moving forward with utilizing \$724,534 Measure J funds for design and installation of three shade structures at the TNC pick-up area.
- Staff have submitted permit documents for a Certificate of Appropriateness.

Next Steps:

- Staff present project documents to Historical Site Preservation Board (HSPB) for their input and approval.

Timeline:

- HSPB presentation is scheduled for April 7, 2026.

Outbound Baggage Handling System Replacement:

Background: This project is intended to modify or replace the existing outbound baggage handling system with a new system to improve capacity and efficiency, enhance baggage tracking through additional technology, reduce or eliminate single points of failure, and improve overall ergonomics for staff.

Status: In Progress

- Swinerton Builders (General Contractor) has been mobilized at the airport.
- Project team have started the site investigation and surveys.

Next Steps:

- General Contractor to finish 90% design drawings for the temporary baggage facility and submit for city staff review and approval.

Timeline:

- 90% design submission is expected to be completed by first week of April.



Restroom Renovations – Design Phase:

Background: City Council approved the design and renovation of all public restrooms Airport-wide in the Fiscal Year 2023 budget. The project includes demolition and replacement of flooring and fixtures, upgrades to ventilation and lighting systems, and the conversion of select restrooms to gender neutral facilities.

Status: In Progress

- Design firm have submitted 90% of the construction documents for staff review.
- Engineering review is complete.

Next Steps:

- City Planning and Fire Review in progress.

Timeline:

- First submittal review is expected by March.

Purchase of (8) Plug-In Electric Vehicle (EV) Pickup Trucks & EV Chargers:

Background: This project involves the procurement of eight (8) zero-emission pickup trucks and four (4) electric vehicle (EV) chargers to replace the existing gas-powered Airport fleet trucks. The purchase supports the Airport's efforts to minimize environmental impact. The project is funded by the Federal Aviation Administration (FAA) through the Airport Zero Emissions Vehicle (ZEV) and Infrastructure Pilot Program.

Status: In Progress

- All eight (8) trucks have been delivered to the city yard.

Next Steps:

- Trucks to be prepped for make-ready equipment and airport use.

Timeline:

- All trucks expected to be in service by April.



(80) Electric Vehicle Chargers Installation:

Background: This project will install 80 Electric Vehicle Charging Systems (EVCS) at parking Lot-B located at the airport. The 80 EVCS consists of 39 dual port charger pedestals and (2) single port pedestals. This project is part of Southern California Edison (SCE) Charge Ready Program & SCE has provided site design and layout. SCE will complete the installation of load-side infrastructure and provide infrastructure to the stub up.

Status: In Progress

- Vendor selection for charger installation is complete.
- Pre-construction kick-off meeting scheduled for 3/10/26.

Next Steps:

- EV charger installation.

Timeline:

- Installation is expected to be completed by mid-April.

Hangar 18 Outfall Repair Project:

Background: Project is to repair the damaged Stormwater Outfalls and damaged pavement due to hurricane Hilary. The scope includes the demolish of the existing security fence, the Stormwater Outfalls and the damaged pavement. Installing new concrete Stormwater Outfalls, new perimeter fence with the new standards.

Status: In Progress

- Project pre-construction meeting with the selected contractor was held in early February.
- Utility relocation is in progress.

Next Steps:

- Utility relocation complete and project mobilization.

Timeline:

- Utility relocation is expected to be completed in March.



FUTURE CITY COUNCIL ACTIONS

March 25, 2026

- TK Elevator Corporation Amendment –Maintenance & Services

April 08, 2026

- Parking Access and Revenue Control Systems (PARCS)
- Kaplan Kirsch Amendment – Legal Consulting Services
- West Aviation Services - San Diego dba Sierra Aviation Group Amendment - Baggage Relocation and Wayfinding Assistance Services
- Air Fayre Lease Agreement

April 22, 2026

- New Monitoring Wells - PFAS - (Engineering)
- Sourcewell/Quinn Company Co-Op Amendment – Generators Maintenance & Services
- ABM Amendment



A Department of the City of Palm Springs

Palm Springs International Airport
3400 E. Tahquitz Canyon Way, Suite 1
Palm Springs, CA 92262-6966

flypsp.com
T: (760) 318-3800

DATE: March 12, 2026
TO: Chairman Corcoran and Airport Commissioners
FROM: Jeremy Keating, Assistant Airport Director
SUBJECT: Assistant Director Report

550 S. Paseo Dorotea -Administration Building (Update)

Background: Given the need for aeronautical space at the Airport to support existing and future tenants, the City Council approved the Airport to proceed with the purchase of 550 S. Paseo Dorotea for \$1.7 million dollars using Measure D dollars and airport revenues. The acquired building will become the administration offices for the Airport. The 8,665 square feet of mezzanine space in the Terminal building will be made available to existing or future tenants at a price per square foot to be negotiated.

Report: The Airport has completed the 60-day due diligence period and has reviewed the inspection report for 550 S. Paseo Dorotea. Items that require attention have been communicated to the seller and the Desert Springs Professional Office business park homeowner's association (HOA). The owner committed \$10,000 towards the repairs while the HOA is working on scheduling the roof repairs to be completed within 60 days of closing. Closing will not be delayed by the scheduled repairs. Closing is scheduled for Monday, March 30th. Closing documents will be transmitted electronically with execution via electronic signatures. The current occupants will remove all furniture and fixtures not part of the structure of the building by close of escrow.

Upon closing of escrow, the Airport will take possession of the building with expected occupancy to start on Wednesday, April 1st. City IT has indicated that they will need 30 days to complete the installation of all required technology. Existing furniture from the Airport will be relocated to 550 S. Paseo Dorotea in accordance with the move in schedule. Items identified that will need to be purchased include four (4) desks, three (3) monitors, a refrigerator and water dispenser. A wall to enclose open space in 550 S. Paseo Dorotea for Airport Security will need to be constructed and a door installed. This work will be done using an on-call contractor. Expected completion will be by May 1st.

The Airport will work on procuring a contract for janitorial services for 550 S. Paseo Dorotea. Until the janitorial services contact can be executed, Airport Maintenance will provide as needed cleaning of the building. The move in schedule will be phased as to minimize disruption to the operations of the Airport. The first group to move will be Capital Development on or about May 1st through 3rd. The second group will be Marketing and Communications, moving in on or about May 8th through 9th. The third group to move in will be the Executive Team on or about May 15th through 16th. Administration will be the fourth

group to move in on or about May 22nd through 24th. The final group will be Airport Security, Operations, and Emergency Management will move in on or about May 29th through May 31st.

Central Terminal Blank Space (Update)

Background: The Airport has been evaluating opportunities to activate the currently vacant space in the Central Terminal lobby to enhance passenger experience while longer-term improvements for the area are developed.

Report: Airport staff recently completed additional improvements to the space to bring it to a more “ready for use” condition so that temporary activations could occur while the long-term concept is finalized. The area has now been cleaned and converted to a white shell condition that can support short term programming during the upcoming festival season. In partnership with FUSE, outreach is currently underway to brands and agencies to secure revenue generating activations tied to the Coachella and Stagecoach travel periods. The longer-term vision for space is to create a welcoming lounge environment that reflects the character and culture of the greater Coachella Valley while providing passengers with comfortable seating, charging stations, integrated flight information displays, and curated information highlighting local attractions and experiences. FUSE is currently advancing sponsorship discussions with potential partners, with Oak View Group and The Living Desert Zoo and Gardens emerging as leading candidates and Cotino being explored as a potential alternative. Sponsorship partners would be thoughtfully integrated into the overall design to ensure the space reflects the destination in an authentic way.

Airport staff, in coordination with FUSE and the Airport Marketing Committee, have been advancing the concept for activating the vacant Central Terminal lobby space through sponsorship and design development. On January 29, 2026, the Airport Marketing Committee met with staff and FUSE, reviewed the initial concept and suggested dedicated digital signage. On February 27, 2026, FUSE confirmed alignment with Airport staff on updated renderings and began working with Penwal to prepare construction plans and required submittals. On March 18, 2026, FUSE presented updated sponsorship and funding options to the Marketing Committee, and staff anticipate confirming a preferred sponsorship structure and final design direction within the next one to two weeks so the project can continue moving forward.

Fabrication has already begun on several primary elements of the space, including the large seating bench that will anchor the lounge area. Staff anticipate aligning a preferred sponsorship structure and final design direction within the next one to two weeks so the project can continue moving forward.

PAST CITY COUNCIL ACTIONS

City Council Regular Meeting for February 25, 2026:

ITEM 1E

SUBJECT:

APPROVE CONTRACT SERVICE AGREEMENTS NO. 26B015 AND 26B016 WITH ADVANTAGE TOTAL PROTECTION, INC. FOR ALARM MONITORING AND MAINTENANCE SERVICES

RECOMMENDATION:

1. Approve Contract Services Agreement No. 26B015 with Advantage Total Protection, Inc. to provide alarm monitoring and maintenance services for the Public Works Department in an amount not to exceed \$525,000, for an initial three-year term from March 1, 2026, through February 28, 2029, with two optional one-year extensions at the City's sole discretion.
2. Approve Contract Services Agreement No. 26B016 with Advantage Total Protection, Inc. to provide alarm monitoring and maintenance services for the Aviation Department in an amount not to exceed \$75,000, for an initial three-year term from March 1, 2026, through February 28, 2029, with two optional one-year extensions at the City's sole discretion.
3. Authorize the City Manager or designee to execute all necessary documents.

ITEM 3C

SUBJECT:

GENERAL FUND, AIRPORT, AND CAPITAL MID-YEAR FISCAL YEAR 2025-26 BUDGET UPDATE

RECOMMENDATION:

Receive and File.

City Council Meeting for March 11, 2026

ITEM 1F

SUBJECT:

APPROVE AMENDMENT NO. 2 TO CONTRACT SERVICES AGREEMENT NO. 24B101 WITH TIMBERLINE GSE, INC. TO PURCHASE FOUR SWITCHBACK PASSENGER BOARDING RAMPS FOR THE PALM SPRINGS INTERNATIONAL AIRPORT

RECOMMENDATION:

1. Approve Amendment No. 2 to Contract Services Agreement No. 24B101 with Timberline GSE, Inc. to purchase four switchback passenger boarding ramps, including two years of warranty and maintenance services, for the Palm Springs International Airport for an additional amount of \$278,000 for a revised contract amount not to exceed \$556,000, and extend the contract term for two years, June 17, 2024, through June 16, 2028.
2. Authorize the City Manager or designee to execute all necessary documents.

[ITEM 1J](#)

SUBJECT:

APPROVE AMENDMENT NO. 1 TO NON-EXCLUSIVE OPERATING AND LEASE AGREEMENT NO. 25L083 WITH ALCLEAR, LLC DBA CLEAR, TO ADJUST COMMERCIAL ACTIVITY FEE BASED UPON CPI, INCLUDE 10% COMMISSION ON MEET AND ASSIST FEE, AND TO INCREASE THE MINIMUM ANNUAL GUARANTEE TO \$131,000 FOR BIOMETRIC PASSENGER SCREENING SERVICES AT THE PALM SPRINGS INTERNATIONAL AIRPORT

RECOMMENDATION:

1. Approve Amendment No. 1 to a Non-Exclusive Operating and Lease Agreement No. 25L083 with Alclear, LLC dba CLEAR to adjust Commercial Activity Fee based upon CPI, include 10% commission on Meet and Assist Fee, and increase the Minimum Annual Guarantee (MAG) for biometric screening services at the Palm Springs International Airport (Airport/PSP).
2. Authorize the City Manager or designee to execute all necessary documents subject to such changes/revisions agreeable to the City Manager and City Attorney.

[ITEM 1K](#)

SUBJECT:

APPROVE AMENDMENT NO. 2 TO LICENSE AGREEMENT A9460 WITH MOBILEMONEY, INC. TO EXTEND THE TERM THROUGH DECEMBER 31, 2026 FOR AUTOMATED TELLER MACHINE (ATM) SERVICES AT THE PALM SPRINGS INTERNATIONAL AIRPORT

RECOMMENDATION:

- Approve retroactively Amendment No. 2 to License Agreement No. A9460 with MobileMoney, Inc. to extend the term through December 31, 2026, for automated teller machine (ATM) services at the Palm Springs International Airport.
2. Authorize the City Manager or designee to execute all necessary documents subject to such changes/revisions agreeable to the City Manager and City Attorney.

[ITEM 1Q](#)

SUBJECT:

APPROVAL OF TWO GRANTS OF EASEMENT TO SPECTRUM PACIFIC WEST LLC ACROSS CITY-OWNED REAL PROPERTY LOCATED AT 305 NORTH CIVIC DRIVE (APN: 502-100-026 AND 502-100-028, AIRPORT PROPERTY)

RECOMMENDATION:

- Approve an Agreement with Spectrum Pacific West LLC granting an easement to install underground communication facilities across a portion of City-owned property, leased to Enterprise, and identified by Assessor's Parcel Number 502-100-026.
2. Approve an Agreement with Spectrum Pacific West LLC granting an easement to install underground communication facilities across a portion of City-owned property, leased to Enterprise, and identified by Assessor's Parcel Number 502-100-028.
 3. Authorize the City Manager or designated staff to execute all documents

[ITEM1R](#)

SUBJECT:

RATIFICATION OF CONSTRUCTION AGREEMENT 25B480 OF AN EMERGENCY CONSTRUCTION CONTRACT IN THE AMOUNT OF \$1,103,944 TO SCHINDLER ELEVATOR CORPORATION FOR AIRPORT PROJECT PSP 26-10, REMOVAL AND REPLACEMENT OF ESCALATORS

RECOMMENDATION:

1. Ratify Construction Agreement 25B480 for Airport Project PSP 26-10, for the Removal and Replacement of Escalators, ("the Project").
2. Delegate authority to the City Manager or designee to approve and execute construction contract change orders up to a total amount of \$110,394 with all change orders reported to the City Council.
3. Authorize the City Manager or designee to execute all necessary documents.

[ITEM1S](#)

SUBJECT:

APPROVE THE FUNDING OF TWO CAPITAL IMPROVEMENT PROJECTS FROM MEASURE J FUNDS FOR THE PALM SPRINGS INTERNATIONAL AIRPORT

RECOMMENDATION:

1. Approve the funding of two capital improvement projects from Measure J funds in an amount not to exceed \$1,500,000 for Palm Springs International Airport.
2. Authorize the City Manager or designee to execute all necessary documents.

Palm Springs International Airport

MONTHLY PASSENGER ACTIVITY REPORT - 2026									
	Enplaned			Deplaned			Total Passengers		
	2026	2025	% Change	2026	2025	% Change	2026	2025	% Change
January	162,179	175,563	-7.6%	168,482	179,223	-6.0%	330,661	354,786	-6.8%
February	193,181	190,572	1.4%	198,420	196,425	1.0%	391,601	386,997	1.2%
March	-	250,084	-100.0%	-	243,366	-100.0%	-	493,450	-100.0%
April	-	210,574	-100.0%	-	195,932	-100.0%	-	406,506	-100.0%
May	-	129,304	-100.0%	-	119,704	-100.0%	-	249,008	-100.0%
June	-	73,003	-100.0%	-	66,717	-100.0%	-	139,720	-100.0%
July	-	63,096	-100.0%	-	61,984	-100.0%	-	125,080	-100.0%
August	-	60,598	-100.0%	-	61,569	-100.0%	-	122,167	-100.0%
September	-	73,951	-100.0%	-	78,822	-100.0%	-	152,773	-100.0%
October	-	122,599	-100.0%	-	135,386	-100.0%	-	257,985	-100.0%
November	-	151,957	-100.0%	-	153,228	-100.0%	-	305,185	-100.0%
December	-	154,330	-100.0%	-	159,153	-100.0%	-	313,483	-100.0%
Year to Date	355,360	1,655,631	-78.5%	366,902	1,651,509	-77.8%	722,262	3,307,140	-78.2%

Palm Springs International Airport

ENPLANED & DEPLANED PASSENGERS - 2026

ENPLANED PASSENGERS														
Airlines	Jan	Feb	Mar	Apr	May	Jun	Jul	Aug	Sep	Oct	Nov	Dec	YTD	FYTD
Air Canada	4,537	5,140											9,677	28,689
Alaska	35,155	43,966											79,121	293,400
American	25,334	28,992											54,326	219,756
Avelo Air	-	-											-	-
Delta Air	17,055	23,595											40,650	107,470
SkyWest (Delta Connection)	4,700	4,700											9,400	49,799
SkyWest (United Express)	9,771	9,793											19,564	95,344
SkyWest (American Air)	2,395	2,880											5,275	31,204
Southwest Air	20,817	24,489											45,306	193,650
United	23,300	26,940											50,240	171,448
WestJet	13,294	15,939											29,233	101,367
Allegiant Air	1,787	1,644											3,431	11,401
Flair	-	-											-	-
Frontier	-	-											-	5,874
Porter	830	901											1,731	3,859
MN Airlines (Sun Country)	3,204	4,202											7,406	23,990
Charters	-	-											-	-
TOTAL ENPLANED	162,179	193,181	-	-	-	-	-	-	-	-	-	-	355,360	1,337,251
DEPLANED PASSENGERS														
Airlines	Jan	Feb	Mar	Apr	May	Jun	Jul	Aug	Sep	Oct	Nov	Dec	YTD	FYTD
Air Canada	4,150	5,280												28,094
Alaska	38,313	44,799												306,348
American	25,862	30,164												230,111
Avelo Air	-	-												-
Delta Air	18,566	25,248												115,839
SkyWest (Delta Connection)	5,039	5,039												52,984
SkyWest (United Express)	9,244	9,553												93,321
SkyWest (American Air)	2,330	3,115												31,135
Southwest Air	20,423	24,972												199,516
United	23,073	25,941												166,257
WestJet	14,860	17,119												110,607
Allegiant Air	1,873	1,642												11,776
Flair	-	-												1,355
Frontier	-	-												4,656
Porter	850	1,013												4,909
MN Airlines (Sun Country)	3,899	4,535												27,038
Charters	-	-												-
TOTAL DEPLANED	168,482	198,420	-	-	-	-	-	-	-	-	-	-	-	1,383,946
TOTAL E & D	330,661	391,601	-	-	-	-	-	-	-	-	-	-	355,360	2,721,197

Palm Springs International Airport

Best Month Comparison							
ENPLANEMENTS							
	2021	2022	2023	2024	2025	2026	Vs Best Mo
Jan	39,614	118,204	169,746	167,926	175,563	162,179	-7.6%
Feb	57,530	142,206	184,973	186,052	190,572	193,181	1.4%
Mar	107,577	202,993	223,314	238,473	250,084	-	-100.0%
Apr	111,376	185,946	200,753	202,219	210,574	-	-100.0%
May	92,820	123,736	129,695	127,314	129,304	-	-100.0%
Jun	66,885	73,861	71,635	68,656	73,003	-	-100.0%
Jul	65,869	68,071	63,647	56,556	63,096	-	-100.0%
Aug	58,793	65,368	59,309	58,673	60,598	-	-100.0%
Sep	65,682	79,599	73,813	69,900	73,951	-	-100.0%
Oct	108,923	120,659	126,702	123,263	122,599	-	-100.0%
Nov	135,677	160,129	162,180	151,801	151,957	-	-100.0%
Dec	136,897	159,846	158,245	163,851	154,330	-	-100.0%
TOTAL	1,047,643	1,500,618	1,624,012	1,614,684	1,655,631	355,360	
% Chg.	-50.89%	43.24%	8.22%	-0.57%	2.54%		
TOTAL PASSENGERS							
	2021	2022	2023	2024	2025	2026	Vs Best Mo
Jan	79,082	237,388	341,656	336,778	354,786	330,661	-6.8%
Feb	120,657	292,336	373,850	382,596	386,997	391,601	1.2%
Mar	214,477	403,883	450,146	472,972	493,450	-	-100.0%
Apr	215,777	358,115	379,353	382,287	406,506	-	-100.0%
May	174,535	233,239	246,186	246,490	249,008	-	-100.0%
Jun	129,872	142,524	138,461	131,639	139,720	-	-100.0%
Jul	129,463	133,664	124,336	112,705	125,080	-	-100.0%
Aug	117,952	129,952	119,256	118,083	122,167	-	-100.0%
Sep	136,666	162,834	151,561	142,688	152,773	-	-100.0%
Oct	225,991	247,457	259,808	258,652	257,985	-	-100.0%
Nov	271,944	319,237	327,470	307,519	305,185	-	-100.0%
Dec	276,527	321,215	325,242	338,505	313,483	-	-100.0%
TOTAL	2,092,943	2,981,844	3,237,325	3,230,914	3,307,140	722,262	
% Chg.	51.17%	42.47%	8.57%	-0.20%	2.36%		

Palm Springs International Airport

ACTIVITY BY AIRLINE
26-Feb

AIRLINES	Enplaned			Deplaned			Total			(E & D)
	2026	2025	% Change	2026	2025	% Change	2026	2025	% Change	Market Share
Air Canada	5,140	6,524	-21.2%	5,280	7,049	-25.1%	10,420	13,573	-23.2%	2.7%
Alaska	43,966	37,985	15.7%	44,799	39,126	14.5%	88,765	77,111	15.1%	22.7%
American	28,992	26,930	7.7%	30,164	26,486	13.9%	59,156	53,416	10.7%	15.1%
Avelo	-	1,734	-100.0%	-	1,742	-100.0%	-	3,476	-100.0%	0.0%
Delta Air	23,595	18,154	30.0%	25,248	18,154	39.1%	48,843	36,308	34.5%	12.5%
SkyWest (Delta Connection)	4,700	3,504	34.1%	5,039	3,541	42.3%	9,739	7,045	38.2%	2.5%
SkyWest (United Express)	9,793	9,819	-0.3%	9,553	10,031	-4.8%	19,346	19,850	-2.5%	4.9%
SkyWest (AA)	2,880	3,570	-19.3%	3,115	3,818	-18.4%	5,995	7,388	-18.9%	1.5%
Southwest Air	24,489	27,956	-12.4%	24,972	28,858	-13.5%	49,461	56,814	-12.9%	12.6%
United	26,940	23,296	15.6%	25,941	24,446	6.1%	52,881	47,742	10.8%	13.5%
WestJet	15,939	19,940	-20.1%	17,119	21,325	-19.7%	33,058	41,265	-19.9%	8.4%
Allegiant Air	1,644	1,858	-11.5%	1,642	2,102	-21.9%	3,286	3,960	-17.0%	0.8%
Flair	-	703	0.0%	-	796	0.0%	-	1,499	0.0%	0.0%
Frontier	-	3,414	-100.0%	-	2,991	-100.0%	-	6,405	-100.0%	0.0%
Porter	901	994	-9.4%	1,013	1,220	-17.0%	1,914	2,214	-13.6%	0.5%
MN Airlines (Sun Country)	4,202	4,191	0.3%	4,535	4,740	-4.3%	8,737	8,931	-2.2%	2.2%
Charters	-	-	0.0%	-	-	0.0%	-	-	0.0%	0.0%
TOTAL	193,181	190,572	1.4%	198,420	196,425	1.0%	391,601	386,997	1.2%	100.0%

PASSENGER ACTIVITY REPORT - FISCAL YEAR COMPARISON

	ENPLANED PASSENGERS						DEPLANED PASSENGERS						TOTAL PASSENGERS								
	FY '25-'26	% CHANGE	FY '24-'25	% CHANGE	FY '23-'24	% CHANGE	FY '22-'23	FY '25-'26	% CHANGE	FY '24-'25	% CHANGE	FY '23-'24	% CHANGE	FY '22-'23	FY '25-'26	% CHANGE	FY '24-'25	% CHANGE	FY '23-'24	% CHANGE	FY '22-'23
July	63,096	↑ 12%	56,556	↓ -11%	63,647	↓ -6%	68,071	61,984	↑ 10%	56,149	↓ -7%	60,689	↓ -7%	65,593	125,080	↑ 11%	112,705	↓ -9%	124,336	↓ -7%	133,664
August	60,598	↑ 3%	58,673	↓ -1%	59,309	↓ -9%	65,368	61,569	↑ 4%	59,410	↓ -1%	59,947	↓ -7%	64,584	122,167	↑ 3%	118,083	↓ -1%	119,256	↓ -8%	129,952
September	73,951	↑ 6%	69,900	↓ -5%	73,813	↓ -7%	79,599	78,822	↑ 8%	72,788	↓ -6%	77,748	↓ -7%	83,235	152,773	↑ 7%	142,688	↓ -6%	151,561	↓ -7%	162,834
October	122,599	↓ -1%	123,263	↓ -3%	126,702	↑ 5%	120,659	135,386	↓ 0%	135,389	↑ 2%	133,106	↑ 5%	126,798	257,985	↓ 0%	258,652	↓ 0%	259,808	↑ 5%	247,457
November	151,957	↑ 0%	151,801	↓ -6%	162,180	↑ 1%	160,129	153,228	↓ -2%	155,718	↓ -6%	165,290	↑ 4%	159,108	305,185	↓ -1%	307,519	↓ -6%	327,470	↑ 3%	319,237
December	154,330	↓ -6%	163,851	↑ 4%	158,245	↓ -1%	159,846	159,153	↓ -9%	174,654	↑ 5%	166,997	↑ 3%	161,369	313,483	↓ -7%	338,505	↑ 4%	325,242	↑ 1%	321,215
January	162,179	↓ -8%	175,563	↑ 5%	167,926	↓ -1%	169,746	168,482	↓ -6%	179,223	↑ 6%	168,852	↓ -2%	171,910	330,661	↓ -7%	354,786	↑ 5%	336,778	↓ -1%	341,656
February	193,181	↑ 1%	190,572	↑ 2%	186,052	↑ 1%	184,973	198,420	↑ 1%	196,425	↓ 0%	196,544	↑ 4%	188,877	391,601	↑ 1%	386,997	↑ 1%	382,596	↑ 2%	373,850
March		↓ -100%	250,084	↑ 5%	238,473	↑ 7%	223,314		↓ -100%	243,366	↑ 4%	234,499	↑ 3%	226,832	-	↓ -100%	493,450	↑ 4%	472,972	↑ 5%	450,146
April		↓ -100%	210,574	↑ 4%	202,219	↑ 1%	200,753		↓ -100%	195,932	↑ 9%	180,068	↑ 1%	178,600	-	↓ -100%	406,506	↑ 6%	382,287	↑ 1%	379,353
May		↓ -100%	129,304	↑ 2%	127,314	↓ -2%	129,695		↓ -100%	119,704	↑ 0%	119,176	↑ 2%	116,491	-	↓ -100%	249,008	↑ 1%	246,490	↑ 0%	246,186
June		↓ -100%	73,003	↑ 6%	68,656	↓ -4%	71,635		↓ -100%	66,717	↑ 6%	62,983	↓ -6%	66,826	-	↓ -100%	139,720	↑ 6%	131,639	↓ -5%	138,461
YTD	981,891	↓ (0.84)	1,653,144	↑ 1%	1,634,536	↑ 0%	1,633,788	1,017,044	↓ (90.12)	1,655,475	↑ 2%	1,625,899	↑ 1%	1,610,223	1,998,935	↓ (1.04)	3,308,619	↑ 1%	3,260,435	↑ 1%	3,244,011

REQUEST FOR PROPOSAL (RFP) & INVITATION FOR BID (IFB) UPDATE

Posted on Planetbids – Bidding

1. **Project Title:** New Monitoring Wells
Bid Posting Date: 02/04/2026 9:29 AM (PST)
Bid Due Date: 03/17/2026 3:00 PM (PST)
Project Type: Bid

Upcoming RFP & IFB to be Posted on Planetbids

- **Project Title (Project Type):**
 1. Airport Landside and Airside Landscaping Services (IFB)
 2. Public Parking Management Services (RFP)
 3. Public Government/Relations (RFP)
 4. Escalator and Elevator Maintenance Services (RFP)
 5. Flooring/wainscoting Services (IFB)
 6. Terminal Restrooms Construction (RFP)

(Contracts over \$150K must be approved by City Council and updates are subject to change)

FUTURE COMMITTEE MEETINGS

Date	Time	Committee
04/15/2026	3:30 P.M.	Noise Committee
04/20/2026	3:30 P.M.	Budget and Finance Committee
TBD	TBD	Ad Hoc Design Review Committee
TBD	TBD	Operations, Properties and Facilities Committee
TBD	TBD	Marketing and Business Development Committee
04/16/2026	9:00 A.M.	Art Review Working Group

ITEM 12.A

AIRPORT COMMITTEES FY2026-27

Revised 03-10-2026

REPRESENTING	COMMISSIONERS	Marketing (9 Members)	Budget (9 Members)	Operations (9 Members)	Noise (5 Members)	Ad Hoc Design Review (6 Members)	Art Review Working Group (2 Members)
Palm Springs	BURKE, Todd	Member			Member	Member	
Palm Springs	CALDWELL, Daniel	Member		Member			
Palm Springs	CORCORAN, Kevin	Member	Member			Chair	
Coachella	Delgado, Denise		Member				
Palm Springs	EBENSTEINER, Bryan	Member		Member			
Palm Springs	FONG, J Craig	Member			Chair		
Palm Springs	HEDRICK, Ken		Chair				
La Quinta	KIEHL, Geoffrey		Member			Member	
Palm Springs	MARTIN, Tracy		Member			Member	
Palm Springs	MCDERMOTT, Sam	Chair					
Riverside County	PARK, Margaret			Member			Member -NON Voting
Cathedral City	SAMLASKA, Christian			Member	Member		Member
Palm Springs	SCHOEFFLER, Timothy			Member	Member		Member
Indian Wells	VALDEZ, Phil		Member	Member			
Desert Hot Springs	VOSS, Dirk		Member	Member			
Palm Desert	WISEMAN, Kevin	Member		Chair	Member	Member	
Indio	WISE, Rick		Member			Member	
Rancho Mirage	YOUNG, Keith	Member		Member		Member	

8 8 9 5 7 2

Request for Proposal (RFP) & Invitation for BID (IFB) Update

Revised 02-12-2026

Blank Slate Space (RFP)	Commissioner Martin
Public Government/Relations (RFP)	Commissioner Schoeffler
Public Parking Management Services (PARCS)	Commissioner Caldwell
Terminal ATMS	Currently in Procurement Queue